

Agilent 16008B Resistivity Cell
Operation and Service Manual



Agilent Technologies

Agilent Part No. 16008-90011
Printed in JAPAN March 2000

Third Edition

Notice

The information contained in this document is subject to change without notice.

This document contains proprietary information which is protected by copyright. All rights are reserved. No part of this document may be photocopied, reproduced, or translated to another language without the prior written consent of the Agilent Technologies.

Agilent Technologies Japan, Ltd.
Component Test PGU-Kobe
1-3-2, Murotani, Nishi-ku, Kobe-shi,
Hyogo, 651-2241 Japan

Warranty

This Agilent Technologies instrument product is warranted against defects in material and workmanship for a period of one year from the date of shipment, except that in the case of certain components listed in this manual, the warranty shall be for the specified period. During the warranty period, Agilent Technologies will, at its option, either repair or replace products which prove to be defective.

For warranty service or repair, this product must be returned to a service facility designed by Agilent Technologies. The Buyer shall prepay shipping charges to Agilent Technologies and Agilent Technologies shall pay shipping charges to return the product to the Buyer. However, the Buyer shall pay all shipping charges, duties, and taxes for products returned to Agilent Technologies from another country.

Agilent Technologies warrants that its software and firmware designed by Agilent Technologies for use with an instrument will execute its programming instruction when properly installed on that instrument. Agilent Technologies does not warrant that the operation of the instrument, or software, or firmware will be uninterrupted or error free.

Limitation of Warranty

The foregoing warranty shall not apply to defects resulting from improper or inadequate maintenance by the Buyer, Buyer-supplied software or interfacing, unauthorized modification or misuse, operation outside of the environmental specifications for the product, or improper site preparation or maintenance.

No other warranty is expressed or implied. Agilent Technologies specifically disclaims the implied warranties of merchantability and fitness for a particular purpose.

Certification

The Agilent Technologies certifies that this product met its published specifications at the time of shipment from the factory. Agilent Technologies further certifies that its calibration measurements are traceable to the United States National Institute of Standards and Technology, to the extent allowed by the Institute's calibration facility, or to the calibration facilities of other International Standards Organization members.

Exclusive Remedies

The remedies provided herein are the buyer's sole and exclusive remedies. Agilent Technologies shall not be liable for any direct, indirect, special, incidental, or consequential damages, whether based on contract, tort, or any other legal theory.

Assistance

Product maintenance agreements and other customer assistance agreements are available for Agilent Technologies products.

If you need assistance, contact your nearest Agilent Technologies Sales and Service Office. Addresses are provided at the back of this manual.

Manual Printing History

The manual printing date and part number indicate its current edition. The printing date changes when a new edition is printed. (Minor corrections and updates which are incorporated at reprint do not cause the date to change.) The manual part number changes when extensive technical changes are incorporated.

March 1992First Edition (part number: 16008-90010)
July 1999Second Edition (part number: 16008-90011)
March 2000Third Edition (part number: 16008-90011)

Safety Summary

The following general safety precautions must be observed during all phases of operation, service, and repair of this instrument. Failure to comply with these precautions or with specific **WARNINGS** elsewhere in this manual may impair the protection provided by the equipment. In addition it violates safety standards of design, manufacture, and intended use of the instrument.

The Agilent Technologies assumes no liability for the customer's failure to comply with these requirements.

Note



16008B is designed for use in INSTALLATION CATEGORY I according to IEC 61010-1 and POLLUTION DEGREE 1 according to IEC 61010-1 and IEC 60664-1. 16008B is an INDOOR USE product.

Do NOT operate in an Explosive Atmosphere

Do *not* operate the instrument in the presence of flammable gasses or fumes. Operation of any electrical instrument in such an environment constitutes a safety hazard.

Keep Away from Live Circuits

Operating personnel must not remove instrument covers. Component replacement and internal adjustments must be made only by qualified maintenance personnel. Do not replace components with the power cable connected. Under certain conditions, dangerous voltages may exist even with the power cable removed. To avoid injury, always disconnect power and discharge circuits before touching them.

Do NOT Service or Adjust While Alone

Do *not* attempt internal service or adjustment unless another person, capable of turning off power and capable of rendering first aid and resuscitation, is present.

Do NOT Substitute Parts or Modify Instrument

Because of the danger of introducing additional hazards, do *not* substitute parts or perform unauthorized modifications to the instrument. Return the instrument to a Agilent Technologies Sales and Service Office for service and repair to ensure the safety features are maintained.

Dangerous Procedure Warnings

Warnings, such as the example below, precede **POTENTIALLY DANGEROUS PROCEDURES** throughout this manual. Instructions contained in the **warnings** must be followed.

Warning



Dangerous voltages, capable of causing death, are present in this instrument. Use extreme caution when handling, testing, and adjusting this instrument.

Safety Symbols

General definitions of safety symbols used on equipment or in manuals are listed below.



Instruction manual symbol: the product is marked with this symbol when it is necessary for the user to refer to the instruction manual.



Alternating current.



Direct current.



On (Supply).



Off (Supply).

Warning



This **Warning** sign denotes a hazard. It calls attention to a procedure, practice, condition or the like, which, if not correctly performed or adhered to, could result in injury or death to personnel.

Caution



This **Caution** sign denotes a hazard. It calls attention to a procedure, practice, condition or the like, which, if not correctly performed or adhered to, could result in damage to or destruction of part or all of the product.

Note



Note denotes important information. It calls attention to a procedure, practice, condition or the like, which is essential to highlight.



Affixed to product containing static sensitive devices use anti-static handling procedures to prevent electrostatic discharge damage to component.



Caution, risk of electric shock : Terminals which may be supplied from the interior of the equipment at a voltage exceeding 1 kV, or allow connection to a voltage exceeding 1 kV are marked with this symbol.

Contents

1. General Information	
Introduction	1-1
Using the 16008B	1-1
Product Description	1-1
Accessories Supplied	1-2
Options	1-2
Operating and Safety Precautions	1-2
Service	1-2
Specifications	1-2
Supplemental Performance Characteristics	1-3
2. Preparation for Use	
Introduction	2-1
Initial Inspection	2-1
Ambient Environmental Considerations	2-3
Operating and Storage	2-3
Using the 16008B in an Environmental Test Oven	2-3
Exchanging the Electrode	2-4
Connecting the Adapter for Use	2-6
Repackaging the Adapter	2-6
3. Operation	
Introduction	3-1
OPEN Correction	3-3
Applying Contact Pressure	3-3
Operation	3-4
Removing the Upper Electrode	3-5
Care of the Electrodes	3-6
Checking Procedure	3-6
4. Service	
Introduction	4-1
Safety Considerations	4-1
Assembly Replacement (General Information)	4-1
Assembly Replacement (Main Body)	4-3
How to start disassembling the main body	4-3
Top Cover Removal	4-3
Micro Switch Adjustment	4-3
Replaceable Parts	4-4
Contact Assembly	4-7
Spring Unit	4-10
Assembly Replacement (Volume/Surface Selector Box)	4-11
Replaceable Parts	4-11
Assembly Replacement (Cable Assembly)	4-12
Do NOT forget Cable Tie	4-12
High Voltage Consideration	4-12

Replaceable Parts	4-12
Assembly Replacement (Upper Electrode)	4-15
Upper Electrode Disassembly	4-15
Replaceable Parts	4-15
Assembly Replacement (Lower Electrodes)	4-18
Disassembly Procedure	4-18
Replaceable Parts	4-18
Troubleshooting	4-20
Schematic Diagram	4-20
Cable Connection Check	4-21
BNC Cable and Triaxial Cable Connection Check	4-21
Interlock Circuit Connection Check	4-22

Figures

2-1. Product Overview	2-2
2-2. 16008B in an Environmental Test Oven	2-4
2-3. Exchanging the Electrode	2-5
2-4. Connecting the Adapter	2-6
3-1. External Appearance	3-1
3-2. Electrode Appearance	3-2
3-3. Load Scale	3-3
3-4. Latch	3-5
4-1. Main Body Disassembly	4-3
4-2. Parts Identification for Contact Assembly	4-8
4-3. Do NOT forget the Cable ties.	4-12
4-4. High Voltage Consideration	4-12
4-5. Cable Connection of 16008B	4-13
4-6. Upper Electrode Disassembly	4-15
4-7. Schematic Diagram of 16008B	4-20
4-8. Cable Connection Check	4-21

Tables

1-1. Furnished Accessories	1-2
1-2. Supplied Options	1-2
2-1. Contents	2-2
4-1. Replaceable Parts (Overview)	4-2
4-2. Replaceable Parts for Main Body (External View)	4-4
4-3. Replaceable Parts for Main Body (Top View)	4-5
4-4. Replaceable Parts for Main Body (Bottom View)	4-6
4-5. Replaceable Parts for Contact Assembly	4-9
4-6. Replaceable Parts for Spring Unit	4-10
4-7. Replaceable Parts for Volume/Surface Selector Box	4-11
4-8. Replaceable Parts for the Cable Assembly	4-14
4-9. Replaceable Parts for Upper Electrode (1 of 2)	4-16
4-10. Replaceable Parts for Upper Electrode (2 of 2)	4-17
4-11. Replaceable Parts for Lower Electrodes	4-19
4-12. 6-pin cable connections	4-22

General Information

Introduction

The purpose of this manual is to enable you to use your 16008B Resistivity Cell efficiently and confidently. This manual contains both general and specific information. To use the 16008B to perform a specific function (without having to read the entire manual), follow the directions in “Using the 16008B”.

Using the 16008B

The 16008B has been designed to operate specifically with the 4339B High Resistance Meter.

- To install the 16008B, turn to Chapter 2.
- To operate the 16008B, turn to Chapter 3.
- To order replaceable parts for the 16008B, turn to Chapter 4.

Product Description

The 16008B has been designed to operate specifically with the 4339B High Resistance Meter. The 16008B is used to measure the volume or surface resistance/resistivity of insulation materials. The 16008B has the following features:

- Electrode size selectable; Three different size electrodes to meet your DUT size requirements and to meet to electrode size requirements required by different standards.
- Can be used in -30 °C to 100 °C ambient environments
- Arbitrary contact pressure can be applied on DUT

Accessories Supplied

The accessories listed in Table 1-1, are supplied with the 16008B:

Table 1-1. Furnished Accessories

Description	Part Number	Quantity
Operation and Service Manual	P/N 16008-90010	1

Options

The following options are supplied for the 16008B:

Table 1-2. Supplied Options

Product Number	Description
16008B	
Option 001	Add 26/76 mm diameter electrodes (with carrying case)
Option 002	Add 26 mm diameter electrode (with carrying case)
Option 003	Add 76 mm diameter electrode (with carrying case)

Operating and Safety Precautions

Service

The voltage levels (up to 1000 V) in this adapter warrants extreme care for operator safety. Service must be performed only by qualified personnel.

Specifications

This section lists the complete 16008B specifications. These specifications are the performance standards and limits against which the 16008B is tested. When shipped from the factory, the 16008B meets the following listed specifications:

Measurement Parameter	Volume Resistance/Resistivity, Surface Resistance/Resistivity
Applicable Test Voltage	1000 V maximum
Applicable Test Current ¹	10 mA maximum
Applicable Instrument	4339B
Interlock Circuit	furnished
Operating Temperature	-30 to 100 °C (connector: 0 to 55 °C)
Operating Humidity	≤70% RH (@40°C)
Cable Length	1.2 m (connector to electrode)
Weight	7 kg
Non-operating Temperature	-40 to 70 °C
Non-operating Humidity	≤95% RH (@40°C)

1. The 4339B limits a maximum test current to 10 mA when using with the 16008B. Maximum measurable current of the 4339B is 100 μ A.

Supplemental Performance Characteristics

This section gives supplemental performance characteristics. Supplemental performance characteristics are not specifications, but are typical characteristics included as additional information for the operator. Supplemental performance characteristics are not guaranteed.

Resistivity Measurement Range ¹
 Volume Resistivity up to 4.0×10^{18} Ω cm
 Surface Resistivity up to 4.0×10^{17} Ω
 Leakage Current ² less than 1.0 pA
 Stability ² less than 0.5 pA
 Applicable DUT (Device Under Test) Size 50 mm to 125 mm diameter
 Applicable DUT Thickness 10 μ m to 10 mm
 Electrode Size

Main Electrode	Guard Electrode ³	Note
ϕ 26 mm	ϕ 38 mm	option
ϕ 50 mm	ϕ 70 mm	furnished
ϕ 76 mm	ϕ 88 mm	option

Operating Load 10 kgF maximum
 Dimensions 240 (W) \times 180 (H) \times 240 (D) [mm]
 Cable Length 1.20 m
 Main body to Selector box 0.82 m

1. After compensation, measurement time is LONG, ϕ 50/70 mm electrode, 23 ± 5 °C, $\leq 50\%$ RH
2. After 1000 V has been applied for 1 minute, in no vibration and shock environment, and under the same conditions as 1
3. Inside diameter

Preparation for Use

Introduction

This chapter explains how to install the 16008B Resistivity Cell. The topics covered include initial inspection, ambient environmental considerations, connecting the adapter for use, and repackaging the adapter for shipping.

Initial Inspection

The adapter has been carefully inspected electrically and mechanically before being shipped from the factory. It should be in perfect physical condition, no scratches, dents or the like, and it should be in perfect electrical condition. Verify this by carefully performing an incoming inspection to check the adapter for signs of physical damage and missing contents. If any discrepancy is found, notify the carrier and Agilent Technologies. Your Agilent Technologies sales office will arrange for repair and replacement without waiting for the claim to be settled.

1. Inspect the shipping container for damage, and keep the shipping materials until the incoming inspection is completed.
2. Verify that the shipping container contains everything shown in Figure 2-1 and listed in Table 2-1.
3. Inspect the exterior of the 16008B for any signs of damage.

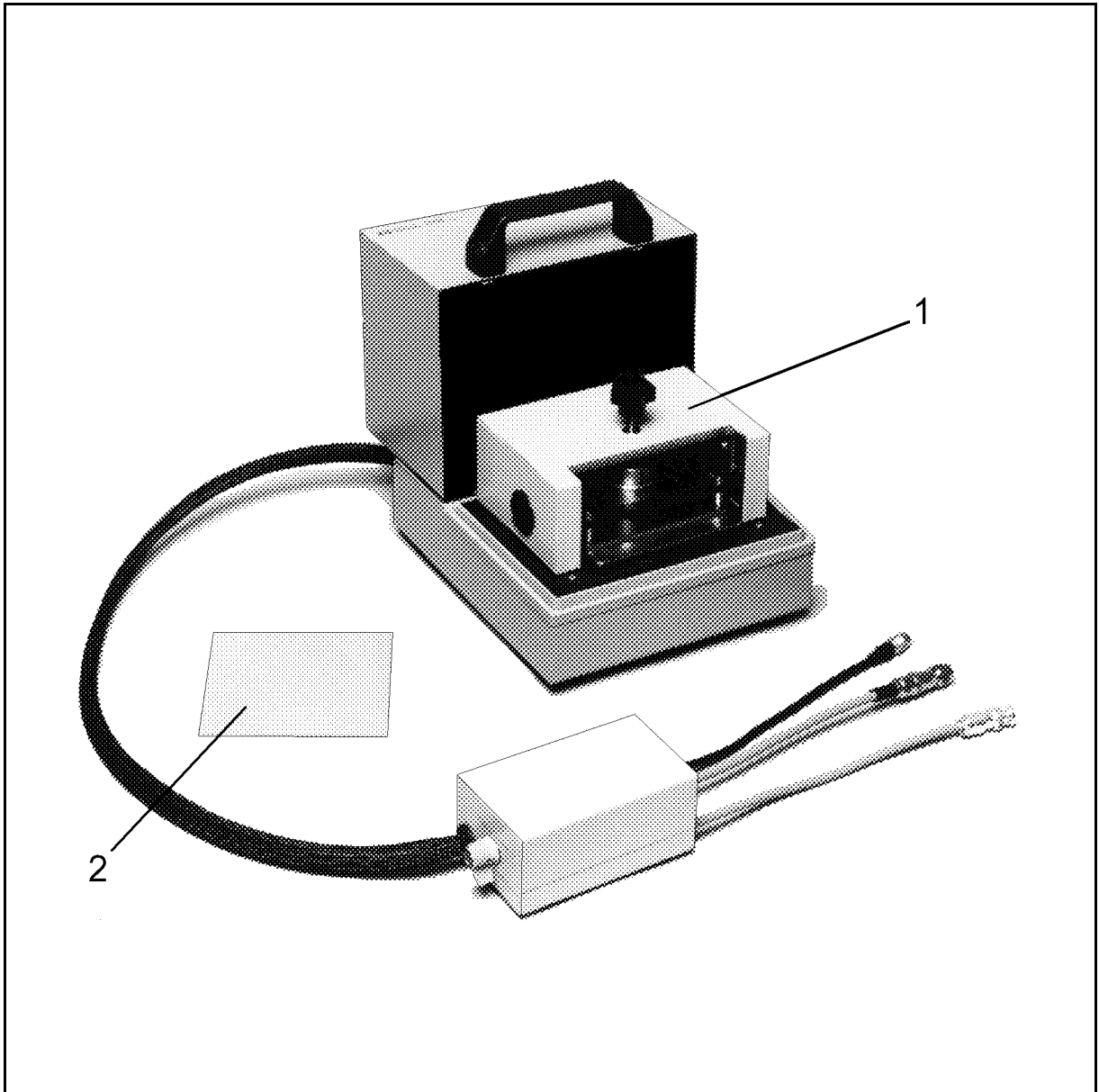

Figure 2-1. Product Overview

Table 2-1. Contents

Description	Agilent Part Number	Quantity
① Resistivity Cell	16008B	1
② Acrylic Plate	16008-1033	1
③ Operation and Service Manual ¹	16008-90020	1

¹ Operation and Service Manual is not shown in Figure 2-1.

2.2 Preparation for Use

When an option is ordered with the 16008B, the following items are included:

Option 001

Description	Agilent Part Number	Quantity
φ26 mm main electrode	16008-60083	1
φ38 mm guard electrode	16008-24084	1
φ76 mm main electrode	16008-60085	1
φ88 mm guard electrode	16008-24086	1
spare screw	0515-0907	3
carrying case	16008-60181	1

Option 002

Description	Agilent Part Number	Quantity
φ26 mm main electrode	16008-60083	1
φ38 mm guard electrode	16008-24084	1
spare screw	0515-0907	3
carrying case	16008-60181	1

Option 003

Description	Agilent Part Number	Quantity
φ76 mm main electrode	16008-60085	1
φ88 mm guard electrode	16008-24086	1
spare screw	0515-0907	3
carrying case	16008-60181	1

Ambient Environmental Considerations

Operating and Storage

The 16008B must be operated within an ambient temperature range of -30°C to $+100^{\circ}\text{C}$ and relative humidity up to 70% RH at 40°C (non-condensing).

The 16008B may be stored within a temperature range of -40°C to $+70^{\circ}$, and at a relative humidity up to 95% at $+40^{\circ}\text{C}$ (non-condensing).

Using the 16008B in an Environmental Test Oven

The 16008B has the capability for high-temperature measurement in environmental testing up to $+100^{\circ}\text{C}$. This section provides information for using the 16008B in an environmental test chamber.

Note



If the environmental test oven temperature exceeds 100°C , the basic specifications will be invalid. You must pay close attention to temperature settings.

The Volume/Surface selector box must be located outside of the oven because it is not designed for operating at temperatures up to 100 °C(see “Specifications” in Chapter 1). To locate the box outside of the oven, the ϕ 100 mm hole is required in the oven. Figure 2-2 shows the measurement configuration when using the 4339B in an environmental test oven.

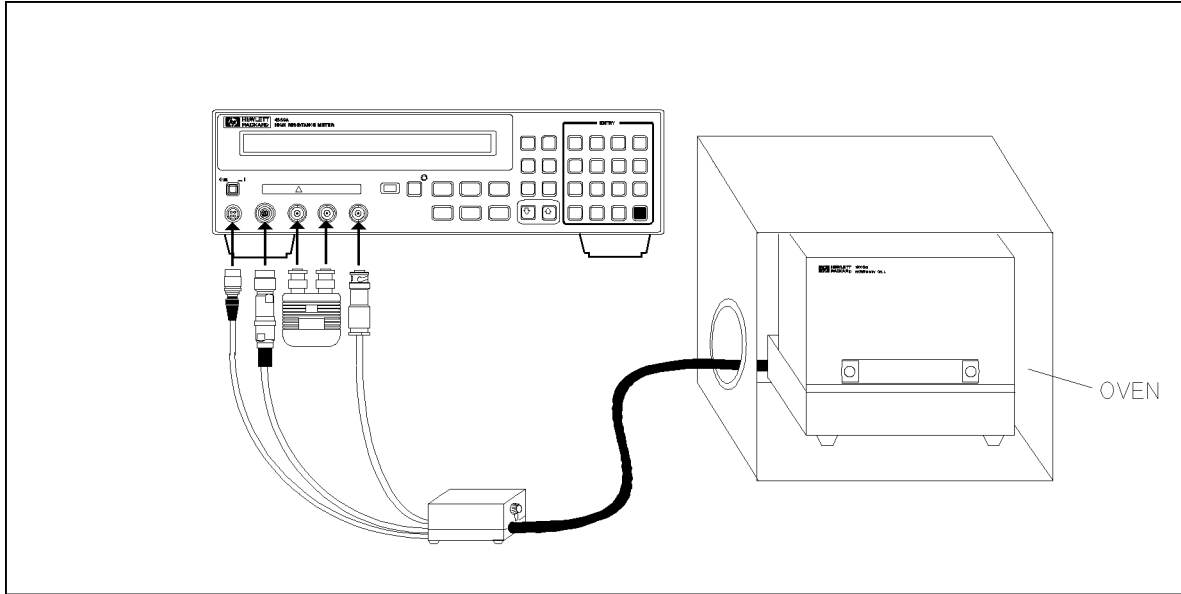

A9102002

Figure 2-2. 16008B in an Environmental Test Oven

Warning



Use globes when handling the 16008B just after it comes out of a test oven or wait until it has cooled down enough to not cause burns.

Exchanging the Electrode

The 16008B has two optional electrodes in addition to the furnished ϕ 50 mm electrode. You can exchange the electrode as required for your measurement. To exchange the electrode, do the following:

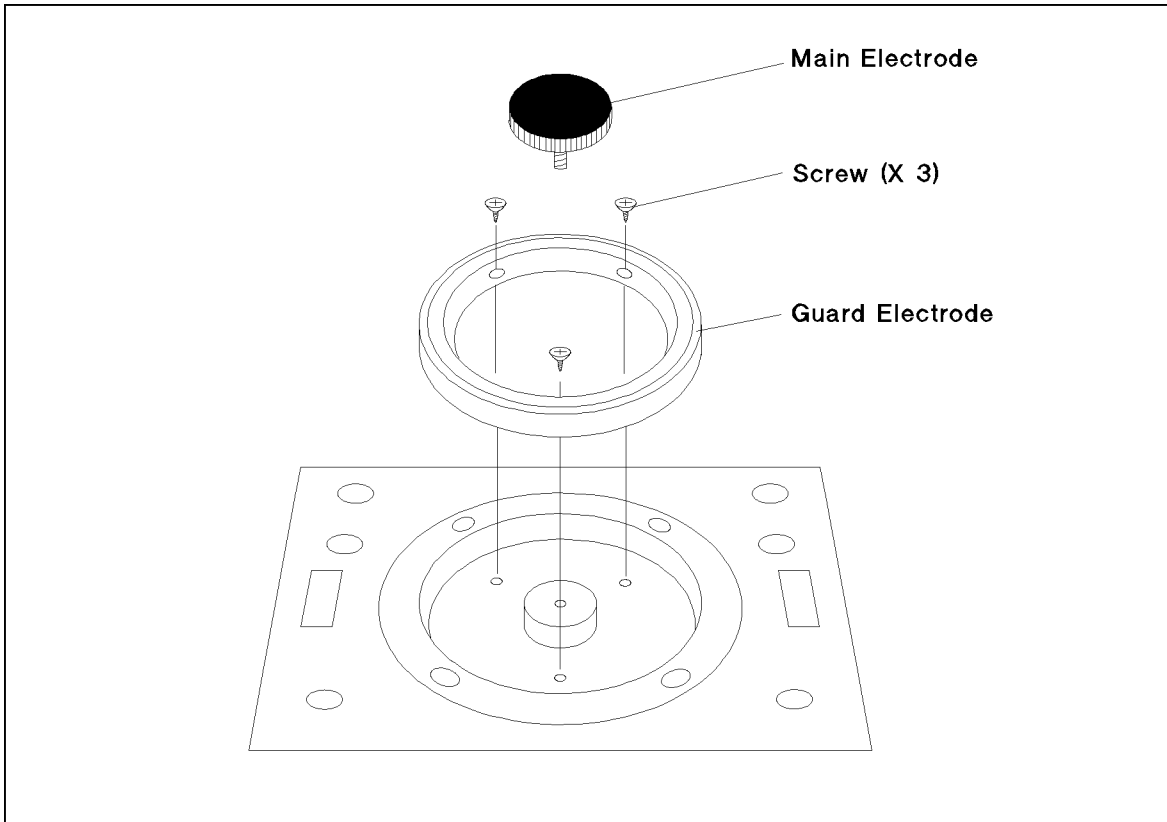

A9102001

Figure 2-3. Exchanging the Electrode

Warning



Do NOT touch the electrode and UNKNOWN connector while the High Voltage indicator is lit which shows the 4339B's output is a high voltage of up to 1000 Vdc maximum. You must operate after turning off the voltage source output and you have confirmed the high voltage indicator is turned off.

To Change Electrodes

1. Turn the main electrode counter clockwise to loosen it, and then remove it.
2. Remove the three screws holding the Guard electrode in place.
3. Remove the Guard electrode.
4. Place the new Guard electrode so that the three holes are aligned with the three holes in the socket module.
5. Insert and Tighten the three screws.
6. Insert the new Main electrode and turn it clockwise to tighten it.
7. Confirm that the top of the Guard electrode sets higher than the top of the Main electrode.

Caution



You must handle the DUT contact of Guard electrode carefully because it is made from a soft material and is easily scratched.

Connecting the Adapter for Use

Connect the 16008B to the 4339B, as shown in Figure 2-4. You must connect BNC, triaxial, and interlock connectors. If the interlock connector is not connected, the 4339B will not output the source voltage.

Warning



Do NOT touch the electrode and UNKNOWN connector while the High Voltage indicator is lit which shows the 4339B's output is a high voltage of up to 1000 Vdc maximum. You must operate after turning off the voltage source output and you have confirmed the high voltage indicator is turned off.

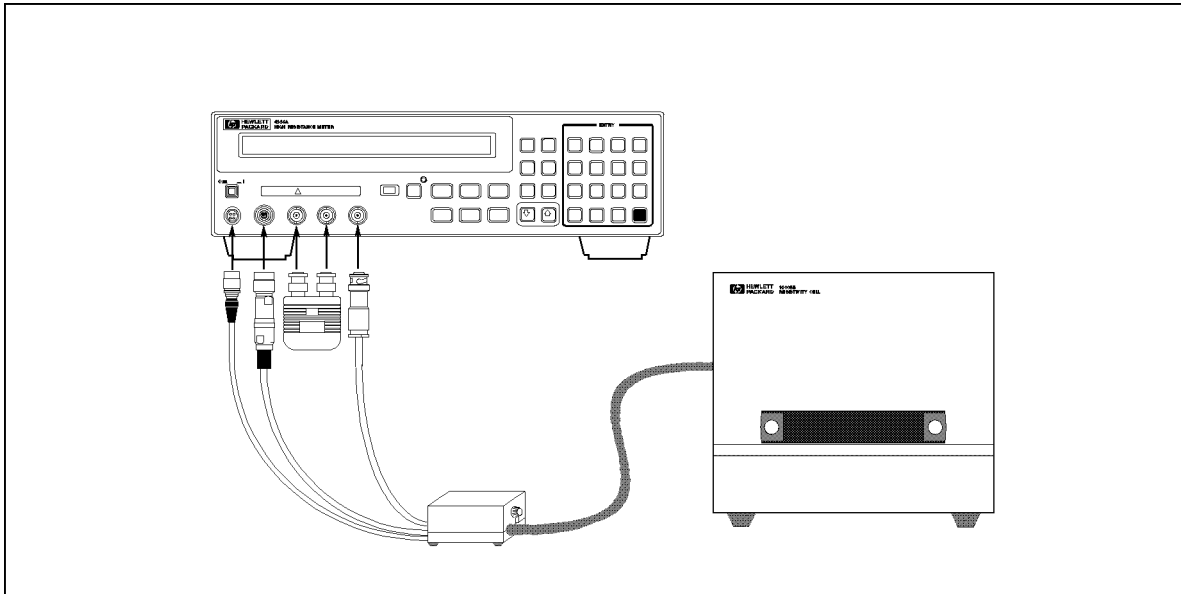

L5006003

Figure 2-4. Connecting the Adapter

Repackaging the Adapter

If shipment to a Agilent Technologies service center is required, each adapter should be repackaged using the original factory packaging materials.

Alternatively, comparable packaging materials may be used. Wrap the adapter in heavy paper and pack in anti-static plastic packing material. Use sufficient shock absorbing material on all sides of the 16008B to provide a thick, firm cushion and to prevent movement. Seal the shipping container securely and mark it *FRAGILE*.

Operation

Introduction

This chapter describes the features of the 16008B, and connections to the 4339B and the DUT.

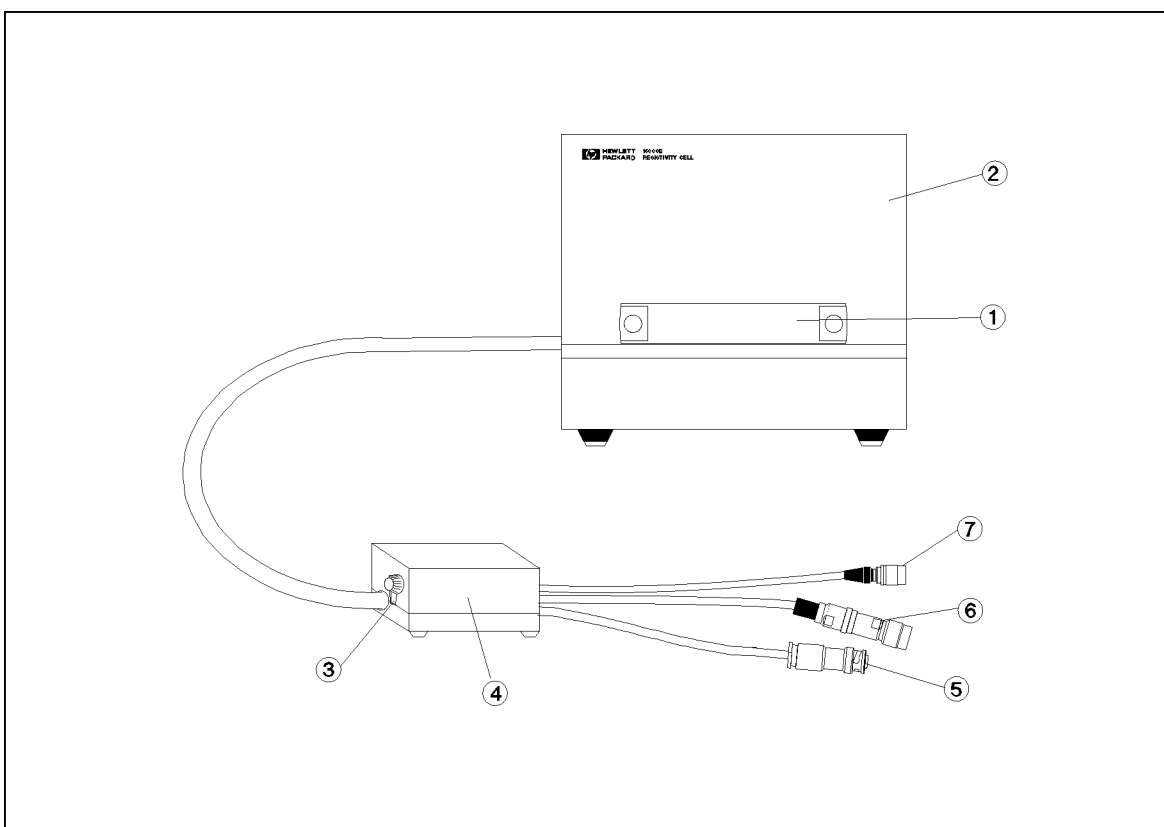

A9103001

Figure 3-1. External Appearance

1. *Handle.*
2. *Top cover.* This shields against external electrical noise and provides an interlock to enable and disable the test voltage when CLOSED and OPEN respectively.
3. *Volume/Surface selector.* Used to select the volume or surface measurement mode. A displayed resistivity parameter would be changed automatically interlocking with selector change. When you operate in manual or external trigger mode, displayed parameter will not change until the 4339B has triggered.

Note

When you change Volume and Surface mode, turn off the source voltage output of the 4339B.



4. *Volume/Surface selector box.*
5. *BNC connector:* This connector supplies the source voltage to the 16008B. This is a high voltage BNC connector and is not compatible with standard BNC connectors.
6. *Triaxial connector:* The measured signal is carried on the center conductor of this connector.
7. *Interlock connector:* This connector enables the interlock function which enables and disables application of the source voltage from the 4339B when the top cover is closed and opened respectively. When the top cover is opened, the source voltage is turned OFF inside the 4339B side.

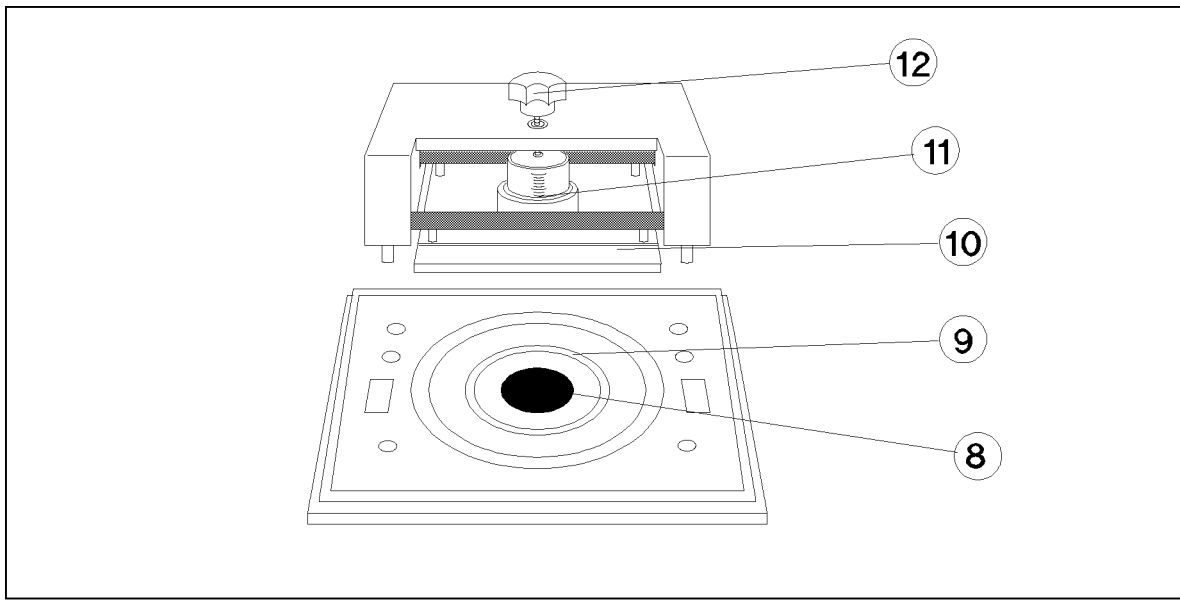

A9103005

Figure 3-2. Electrode Appearance

8. *Main electrode.* (covered with a conductive elastomer) The negative test voltage is applied from the Output terminal of the 4339B.
9. *Guard electrode.* Provides the guard for Volume measurements. Applies the positive test voltage for surface measurements.
10. *Upper electrode.* Provides the guard for surface measurements. Applies the positive test voltage for volume measurements.
11. *Load scale.* This scale shows currently applied pressure in kilograms.
12. *Load knob.* To apply load for the DUT, turn this knob to clockwise.

OPEN Correction



OPEN correction compensates cancels residual resistance for resistance measurements.

Warning



Do NOT touch the electrodes and UNKNOWN connector while the High Voltage indicator is lit which shows the 4339B's output is a high voltage of up to 1000 Vdc maximum. You must operate after turning off the voltage source output and you have confirmed the high voltage indicator is turned off.

OPEN Correction Procedure

1. Turn the load knob counterclockwise(ccw) until the upper electrode does not move.
2. Select the current measurement mode at the 4339B.
3. Close the top cover.
4. Apply the source voltage required for your measurement at the 4339B.
5. Set measurement time to LONG and wait until the current has stabilized to within 0.5 pA.
6. Press   keys of the 4339B to perform the OPEN correction.

Note



When an OPEN correction is performed, the electrodes must be separated enough to prevent leakage current from occurring which will lead to OPEN correction instability.

Note



Do NOT allow vibration to reach the 16008B when performing an OPEN correction. The upper electrode of the 16008B is not fixed when setup for an OPEN correction, and vibration will cause the upper electrode to move about leading to OPEN correction instability.

Applying Contact Pressure

The 16008B can apply contact pressure on the DUT of up to approximately 10 kg. The contact pressure Load Scale shows the approximately applied contact pressure in kilograms. To adjust the contact pressure, turn the load knob clockwise (cw). Figure 3-3 shows how to read the load scale.

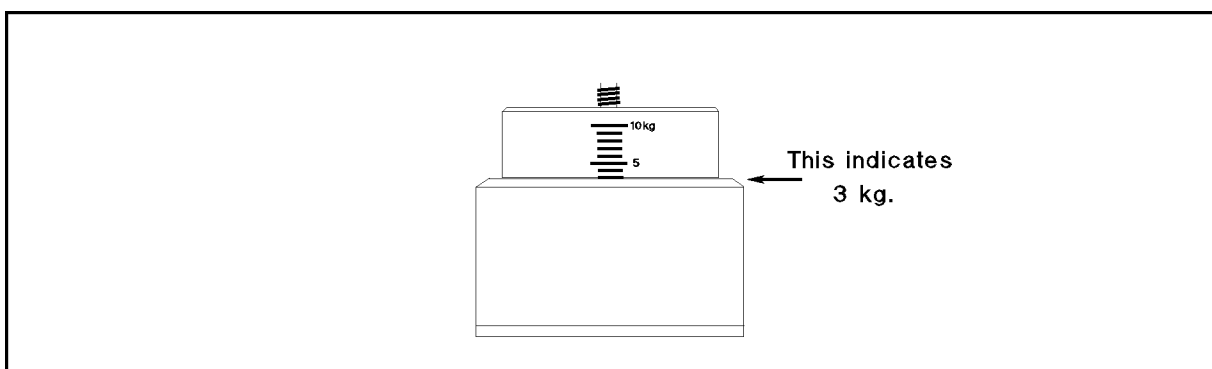

A9103002

Figure 3-3. Load Scale

Caution

Do NOT adjust the contact pressure setting past the 10 kg mark or the 16008B may be mechanically damaged.

Operation

Step-by-step instructions on how to make a measurement with the 16008B are as follows:

Warning

Do NOT touch the electrode and UNKNOWN connector while the High Voltage indicator is lit which shows the 4339B's output is a high voltage of up to 1000 Vdc maximum. You must operate after turning off the voltage source output and you have confirmed the high voltage indicator is turned off.

1. Connect the Triaxial connector to the INPUT terminal, the BNC connector to the OUTPUT terminal, and the Interlock connector to the Interlock terminal of the 4339B.
 2. Select either a surface or a volume measurement using the Volume/Surface selector.
-

Note

Turn off the voltage output when you change the Volume/Surface selector. If you change the Volume/Surface selector when voltage applied, a calibration, open correction, or offset-error cancel of the 4339A would be failed due to noise generated from the Volume/Surface selector.

3. Perform an OPEN correction as described in "OPEN Correction".
 4. Place the DUT on the Main electrode, and then place the upper electrode on the DUT.
 5. Turn the contact pressure load knob to adjust the electrode contact pressure on the DUT. Refer to "Applying Contact Pressure".
 6. Close the Top cover. The 16008B measurement preparation is now complete.
 7. Follow the measurement instructions described in the *4339A Operating Manual* to perform the measurement.
-

Caution

Do NOT short the upper and lower electrodes when the voltage source is turned on.

Note

For surface and volume measurements, different voltage polarities are applied to the DUT. When changing between surface and volume measurements, the 4339B requires a settling time of at least one minute.

Removing the Upper Electrode

Warning



Do NOT touch the electrode and UNKNOWN connector while the High Voltage indicator is lit which shows the 4339B's output is a high voltage of up to 1000 Vdc maximum. You must operate after turning off the voltage source output and you have confirmed the high voltage indicator is turned off.

To Remove Upper Electrode

1. Push the latch on both sides of the upper electrode. See Figure 3-4. The lock will then be released.
2. Lift the upper electrode up and remove it.

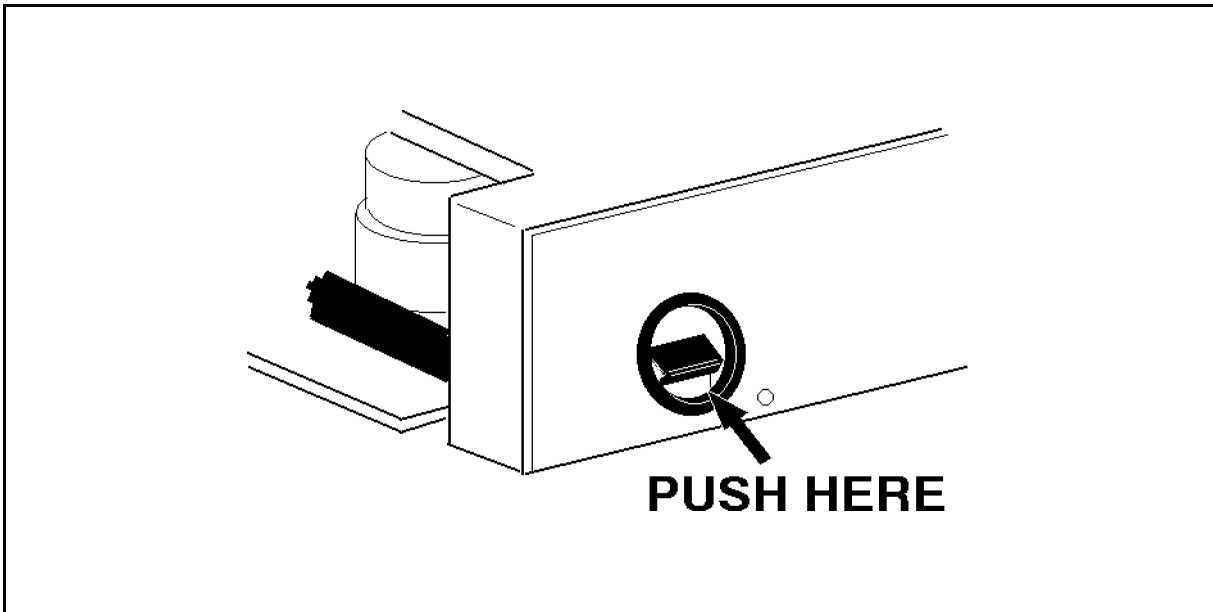

Figure 3-4. Latch

Note



The upper electrode may not release when you push the latch and a contact pressure load is still applied. If this happens turn the contact pressure load knob CCW to decrease the applied pressure, until the upper electrode releases.

Care of the Electrodes

The electrodes should be kept clean to obtain complete contact with the DUT. To clean the electrodes (except for the conductive elastomer), wipe them with a dust free cloth that has been dipped in alcohol.

To avoid scratching the guard electrode when the 16008B is not in use, place the furnished acrylic plate between upper and guard electrodes, and apply a pre-load contact pressure to firmly hold the acrylic plate in place.

Warning



Do NOT touch the electrode and UNKNOWN connector while the High Voltage indicator is lit which shows the 4339B's output is a high voltage of up to 1000 Vdc maximum. You must operate after turning off the voltage source output and you have confirmed the high voltage indicator is turned off.

Checking Procedure

The 16008B and the 4339B is operated with high voltage up to 1000 V. These products are designed that the operator can measure safely. To keep the safe condition, you must execute following checking procedure periodically.

Warning



Do NOT touch the electrode and UNKNOWN connector while the High Voltage indicator is lit which shows the 4339B's output is a high voltage of up to 1000 Vdc maximum. You must operate after turning off the voltage source output and you have confirmed the high voltage indicator is turned off.

Daily Safety Verification Procedure

1. Connect the 16008B to the 4339B.
2. Close the top cover of the 16008B.
3. Set source voltage to 42 V.
4. Press V output key of the 4339B.
Confirm that the V output indicator and the High Voltage indicator turn on.
5. Open top cover of the 16008B.
Confirm that the High Voltage indicator turns off immediately.
6. Close the top cover again.
Confirm that the High Voltage indicator still turns off.

If you encountered any errors in checking procedure, contact your nearest Agilent Technologies Office.

Service

Introduction

This chapter covers the following subjects:

- Assembly Replacement
 - Disassembly Procedure for main assembly
 - Replaceable Parts
- Troubleshooting

Safety Considerations

This manual contains CAUTIONs which must be followed to ensure the safety of the operator and to keep the instrument in a safe and serviceable condition.

Warning



These servicing instructions are for use by qualified personnel only. Do NOT perform any servicing other than that contained in the operating section unless you are qualified to do so.

Assembly Replacement (General Information)

Table 4-1 shows all items included with the 16008B. Detailed explanations for the following five parts are given in the sections which follow:

- Main Body
- Volume/Surface Selector Box
- Cable Assembly
- Upper Electrode
- Lower Electrodes

Table 4-1. Replaceable Parts (Overview)

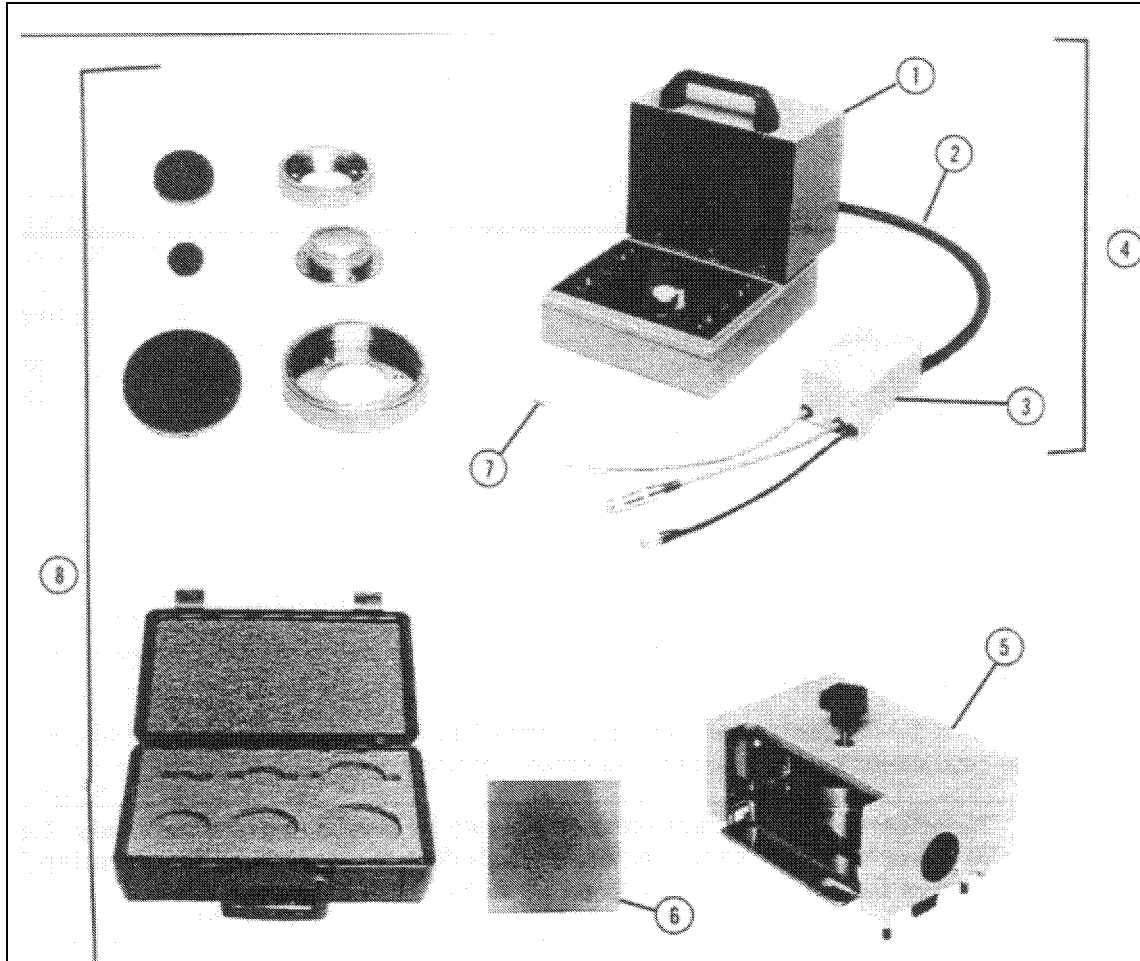

Reference Designator	Agilent Part Number	Qty.	Description
1	Not Assigned	1	Main body
2	Not Assigned	1	Cable Assembly
3	Not Assigned	1	Volume/Surface Selector Box
4	16008-60051	1	Main Fixture Assembly ¹
5	16008-60071	1	Upper Electrode Assembly
6	16008-1033	1	Acrylic Plate
7	0515-0907	3	Screw Pan M3L8 (for guard electrode)
8	Not Assigned	1	Lower Electrodes ²
-	16008-90011	1	Operation and Service Manual ³

1 includes Items 1 through 3.

2 See "Assembly Replacement (Lower Electrodes)" for each lower electrode.

3 isn't included in the above picture.

Assembly Replacement (Main Body)

This section explains complex and important points when disassembling and assembling the Main Body. The replaceable Parts List for the main body is also provided in this section.

How to start disassembling the main body

Open the box from the top when replacing the electrodes and parts around the electrodes. Open the box from the bottom when repairing the electrical connections. The following describes how to open the box from the top.

1. Remove both the main electrode and the guard electrode shown in “Exchanging the Electrode” in Chapter 2.
2. Remove the black plate by removing the two screws (marked with ①).
3. Remove the black insulator by removing the three screws (marked with ②).

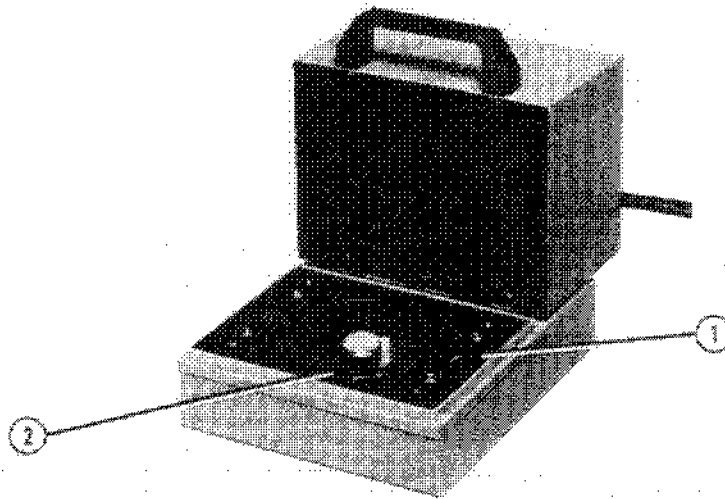

Figure 4-1. Main Body Disassembly

Top Cover Removal

Before removing the top cover, the screw, which pushes the micro switch closed, should be removed from the top cover. This screw is accessed by removing the bottom cover, it is mounted on the portion of the top cover which extends down into the box.

Micro Switch Adjustment

When the top cover or the micro switch is reassembled, the length of the screw which pushes the micro switch (P/N 16008-24051) closed must be adjusted so that it will cause the micro switch to open at the proper top cover opening angle.

1. Put a drop of Lock-Tite (P/N 0470-0013) on the screw's threads.
2. Rotate the screw clockwise until you hear the micro switch click closed (or use the low resistance range of a multimeter and watch for the resistance change when the switch closes).
3. Rotate the screw one more full turn clockwise.

Replaceable Parts

Table 4-2 through Table 4-4 show and list the replaceable parts for the main body. The parts listed can be ordered from your nearest Agilent Technologies Office. Ordering information must include the Agilent part number and the quantity required.

Table 4-2. Replaceable Parts for Main Body (External View)

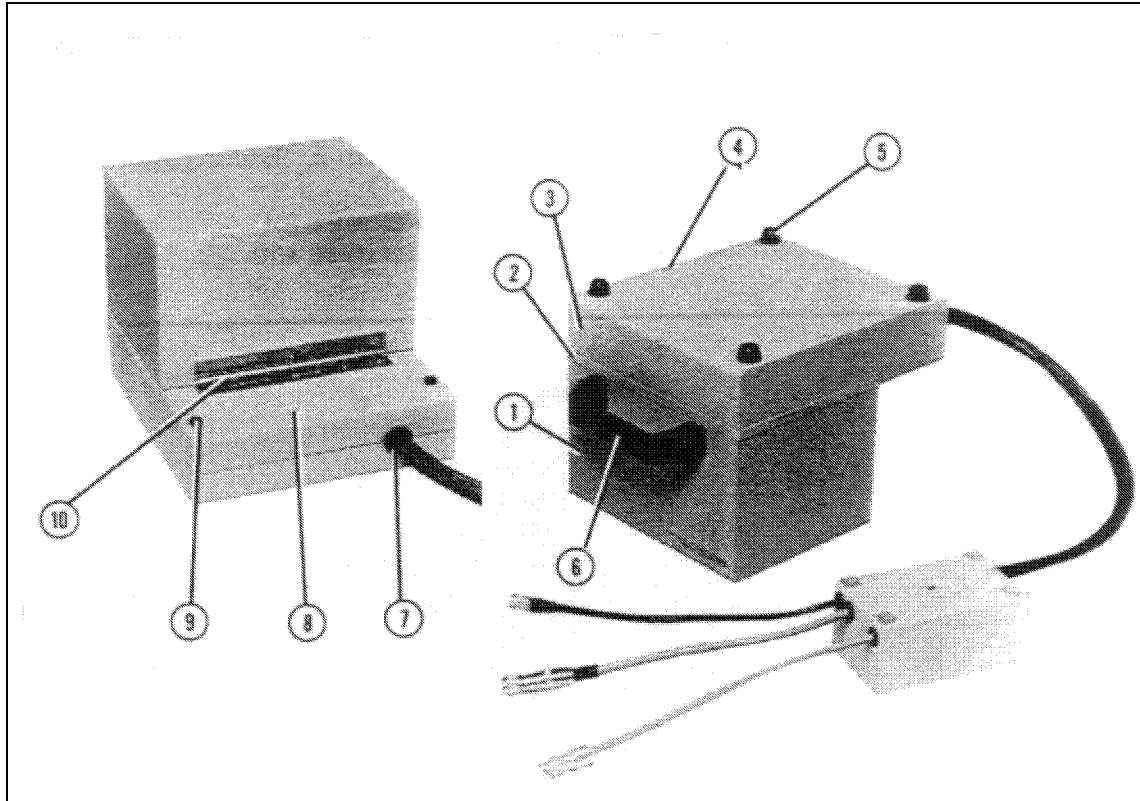

Reference Designator	Agilent Part Number	Qty.	Description
1	16008-60052	1	Top Cover
2	16008-40051	1	Trim Personal
3	16008-60053	1	Bottom Cover
4	0515-0914	2	Screw Flat M3L6
5	0403-0712	4	Bumper Foot
	0515-1551	4	Screw Pan M3L10
6	1440-0186	1	Handle
	0515-2415	2	Screw M8L16
7	0400-0276	2	Grommet
8	16008-00251	1	Panel Top ¹
9	0403-0316	2	Bumper Foot
10	16008-09051	1	Hinge
	0515-0907	3	Screw Flat M3L8
	0515-0914	3	Screw Flat M3L6

¹ One machine screw (P/N 0515-0914) on this panel. (not included in the above picture.)

Table 4-3. Replaceable Parts for Main Body (Top View)

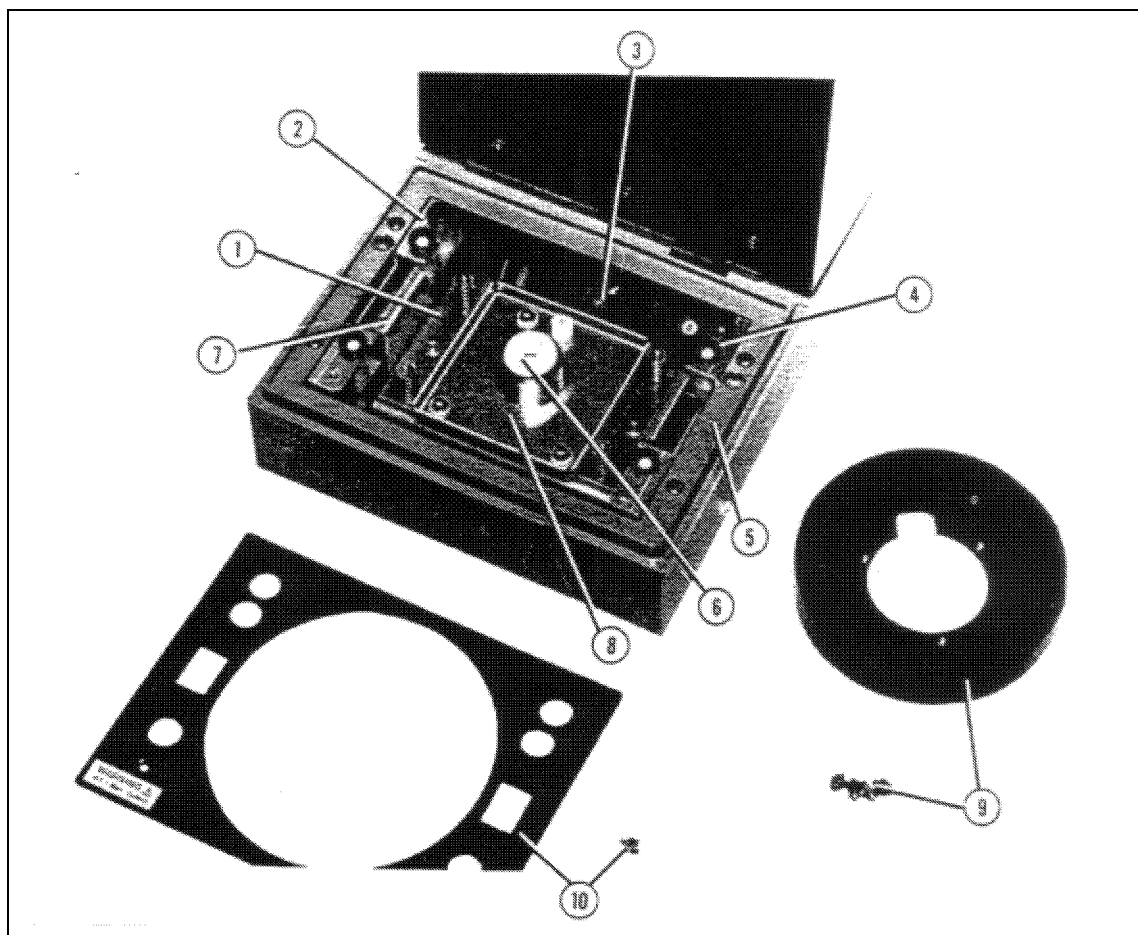

Reference Designator	Agilent Part Number	Qty.	Description
1	16008-00151	1	Chassis
2	16008-60054	1	Spring Unit Assembly
3	16008-61657	1	Cable Assembly(White Label)
	1400-1653	1	Cable Tie
	1400-0054	1	Clamp Cable
	0515-2079	1	Screw Pan M4L8
4	16008-60055	1	Spring Unit Assembly
5	16008-40051	1	Trim Personal
6	16008-60087	1	Contact Assembly ¹
7	16008-00153	1	Chassis
8	16008-00651	1	Plate
9	16008-25081	1	Insulator
	0515-1550	4	Screw Flat M3L8
	3050-0891	4	Washer
10	16008-00252	1	Panel
	0515-0914	1	Screw Flat M3L6

¹ See "Contact Assembly" for details.

Table 4-4. Replaceable Parts for Main Body (Bottom View)

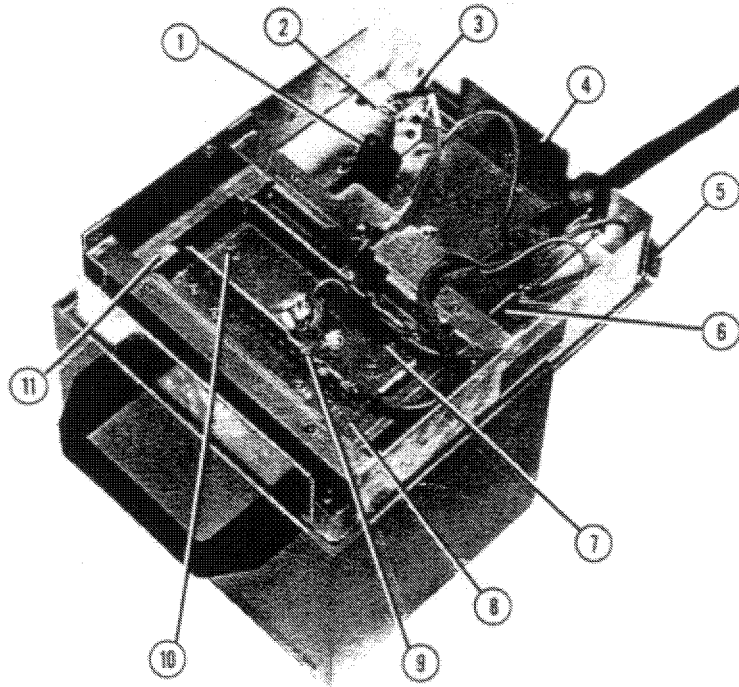

Reference Designator	Agilent Part Number	Qty.	Description
1	16008-24051	1	Screw to push the microswitch
2		1	Microswitch
		1	Switch Cover
3	16008-68051	1	Jumper Wire ¹
4	16008-00151	1	Chassis
5	16008-00251	1	Panel Top
6	1400-0054	1	Clamp Cable
	0515-2079	1	Screw Pan Head
7	16008-00153	1	Chassis
8	16008-60055	1	Spring Unit Assembly
9	1400-1653	6	Cable Tie
10	0515-0914	2	Screw Flat Head
11	16008-60054	1	Spring Unit Assembly

¹ Includes nuts and bolts to mount the microswitch.

Caution

1. Use the cable tie specified in the list because it is a special cable tie which can withstand high temperatures.
 2. When disassembling the top cover, the screw which pushes the micro switch closed must be removed first. See “Top Cover Removal” for details.
 3. When reassembling the top cover or the micro switch, the screw which pushes the micro switch closed must be adjusted to let the micro switch open at the proper opening angle of the top cover. See “Micro Switch Adjustment” for details.
-

Contact Assembly

Figure 4-2 and Table 4-5 show the replaceable parts for the contact assembly in the main body.

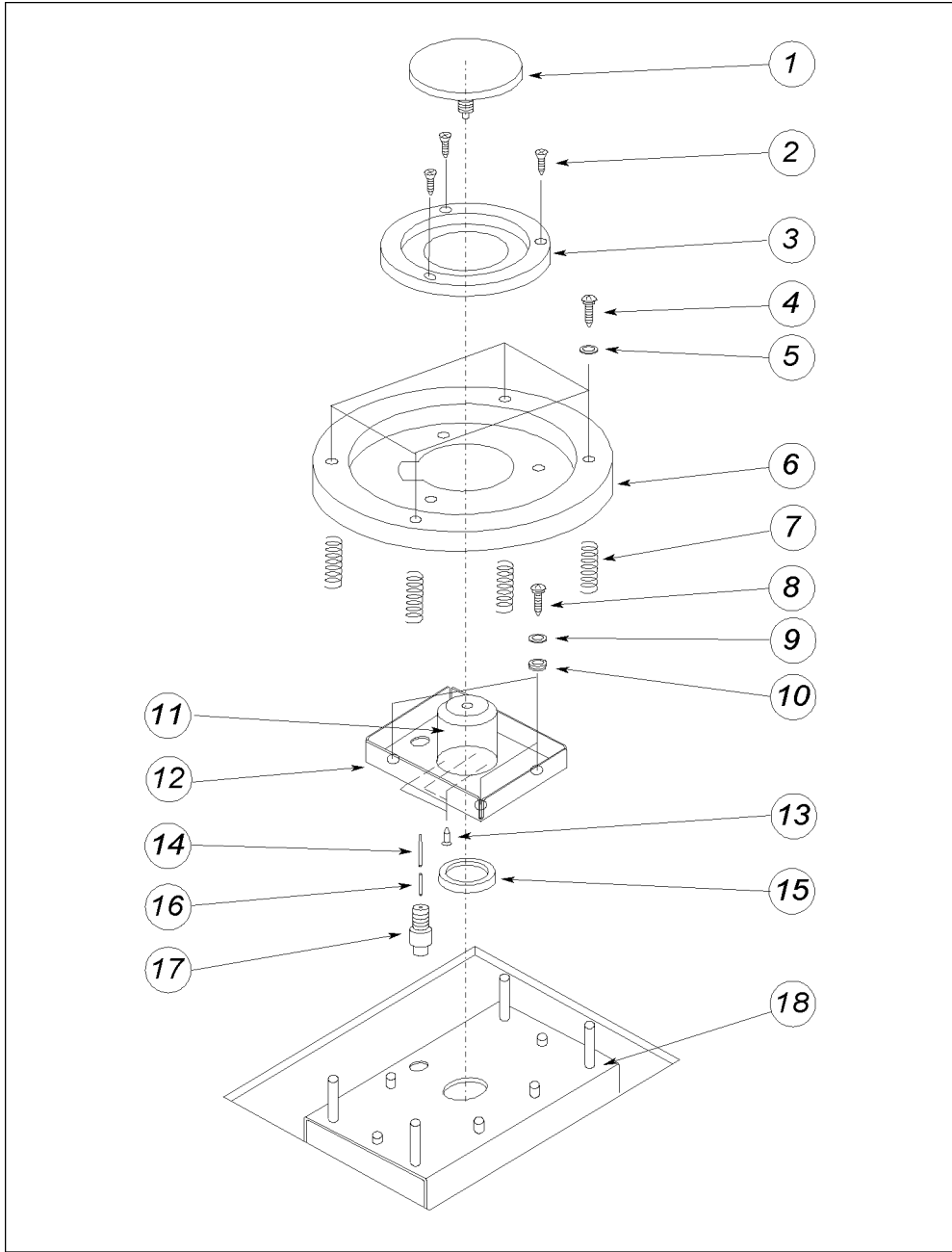

A91OS004

Figure 4-2. Parts Identification for Contact Assembly

Table 4-5. Replaceable Parts for Contact Assembly

Reference Designator	Agilent Part Number	Qty.	Description
1	16008-60081	1	Main Electrode(ϕ 50mm)
2	0515-0907	3	Screw Flat M3L8
3	16008-24082	1	Guard Electrode
4	0515-1550	4	Screw Pan M3L8
5	3050-0891	3	Washer
6	16008-25081	1	Insulator
7	1460-0323	4	Spring
8	0515-1550	3	Screw Pan M3L8
9	3050-0891	3	Washer
10	16147-25001	3	Insulator
11	16008-60087	1	Contact Assembly ¹
12	16008-00651	1	Plate
13	0515-1076	3	Screw Flat Head
14	0360-2066	1	Contact Pin
15	16008-25085	1	Spacer
16	0360-2082	1	Contact-signal Contact
17	16008-25084	1	Insulator
18	16008-00151	1	Chassis

¹ Do not disassemble it further because a special tool is required to assemble it.

Caution



Before disassembling the Contact Assembly, remove the electrical connections at the bottom of box.

Spring Unit

Table 4-6 shows the spring unit in the main box.

Table 4-6. Replaceable Parts for Spring Unit

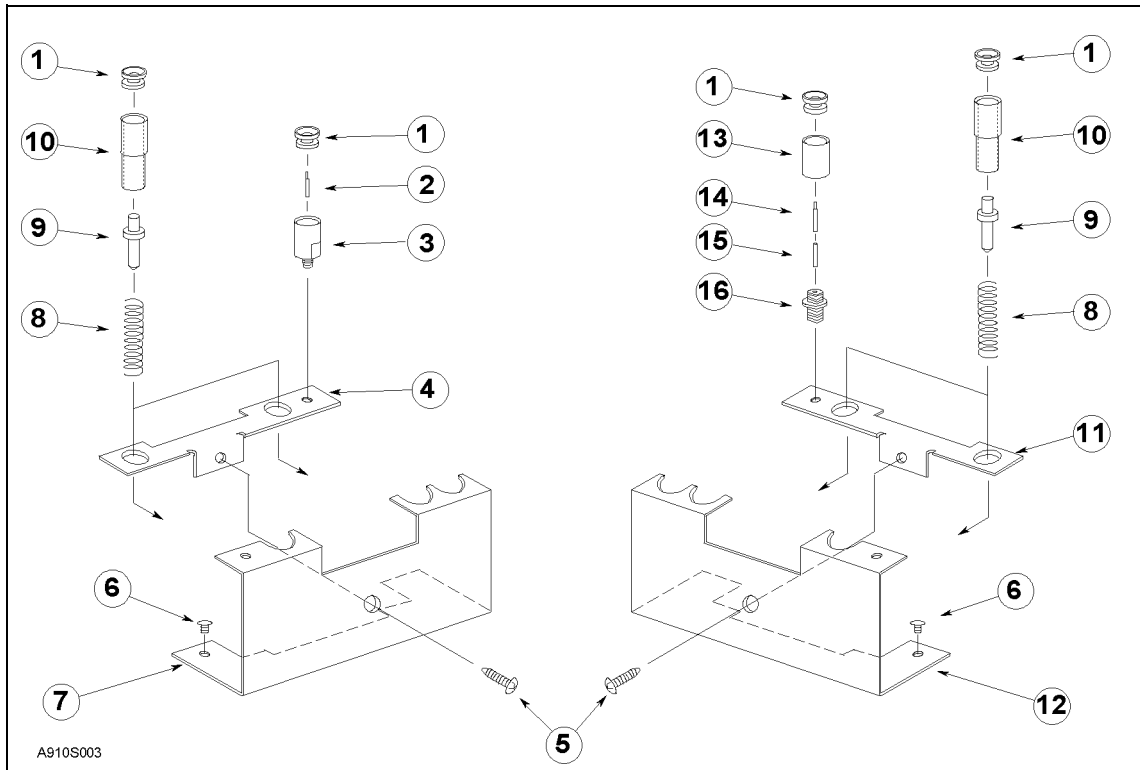

A910S003

Reference Designator	Agilent Part Number	Qty.	Description
1	16008-25025	6	Bushing
2	8710-1951	1	Probe Contact
3	16008-24052	1	Terminal
4	16008-01256	1	Angle Bracket
5	0515-0914	2	Screw Flat M3L6
6	0515-1550	4	Screw Pan M3L8
7	16008-01254	1	Angle Bracket
8	1460-2238	4	Spring
9	16008-25055	4	Bushing
10	16008-25053	4	Spacer
11	16008-01257	1	Angle Bracket
12	16008-01255	1	Angle Bracket
13	16008-25054	1	Insulator
14	0360-2066	1	Contact Assembly
15	0360-2082	1	Connection-signal Contact
16	16008-25084	1	Insulator

Assembly Replacement (Volume/Surface Selector Box)

This section explains about the replaceable parts for the volume/surface selector box.

Replaceable Parts

Table 4-7 shows the replaceable parts for the Volume/Surface Selector Box. See also “Assembly Replacement (Cable Assembly)” for the cable connections. The parts listed can be ordered from your nearest Agilent Technologies Office. Ordering information must include the Agilent part number and the quantity required.

Table 4-7. Replaceable Parts for Volume/Surface Selector Box

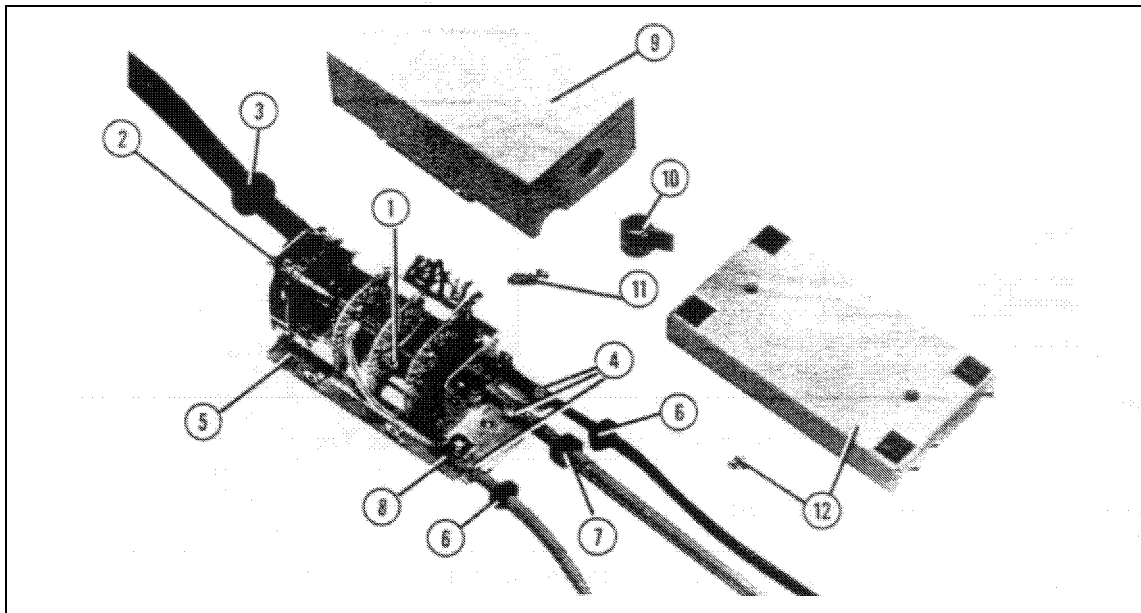

Reference Designator	Agilent Part Number	Qty.	Description
1	3100-3505	1	Switch Rotary ¹
2	16008-01263	1	Angle Bracket
3	0400-0276	1	Grommet
4	1400-1653	7	Cable Tie
5	0400-0010	2	Grommet
6	0411-0306	1	Grommet
7	0515-2079	1	Screw Pan M4L8
	1400-0054	1	Clamp Cable
8	16008-04065	1	Top Cover
9	0370-2994	1	Knob
10	0515-0914	5	Screw Flat M3L6
11	16008-60062	1	Bottom Cover
12	16008-01264	1	Angle Bottom
13	0515-0914	2	Screw Flat M3L6

¹ Includes a nut and washers.

Assembly Replacement (Cable Assembly)

This section explains about the replaceable parts for the cable assembly.

Do NOT forget Cable Tie

Caution



When reassembling cables, do NOT forget to tighten the cable ties. Cable ties shown in Figure 4-3 are used to fix the cables in the fixture assemblies and should NOT be forgotten in any time.

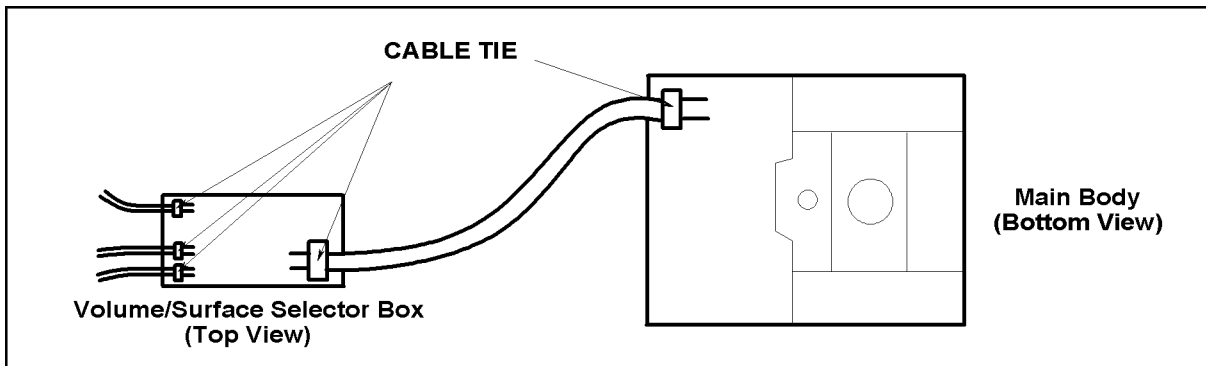

A910S013

Figure 4-3. Do NOT forget the Cable ties.

High Voltage Consideration

The cables shown in Figure 4-4 have an approximately 1000 V voltage inside of the cable. Do not put this cable less than 8 mm close to any conductive device.

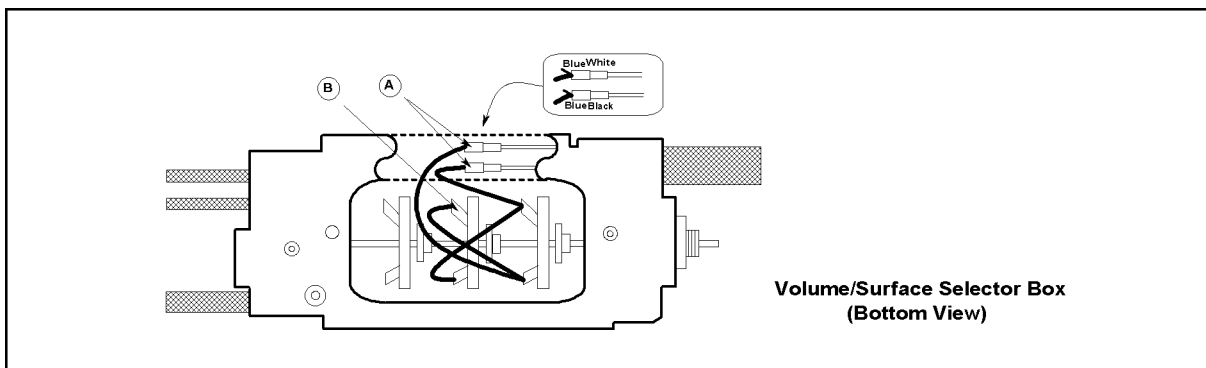

A910S012

Figure 4-4. High Voltage Consideration

Replaceable Parts

Table 4-8 shows the replaceable parts for the cable assembly. Figure 4-5 shows the connection of these cables. The parts listed parts can be ordered from your nearest Agilent Technologies Office. Ordering information must include the Agilent part number and the quantity required.

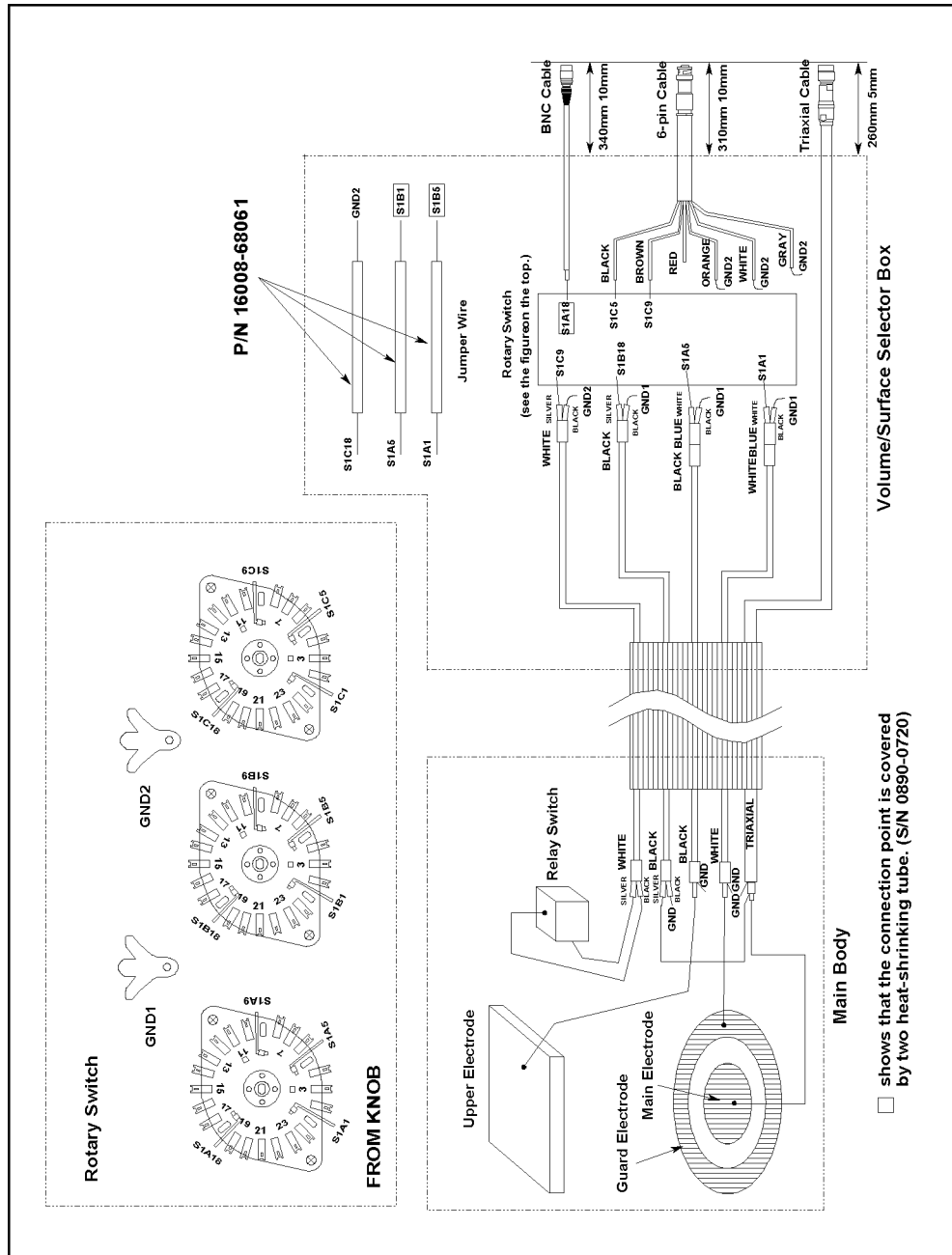

A910S005

Figure 4-5. Cable Connection of 16008B

Table 4-8. Replaceable Parts for the Cable Assembly

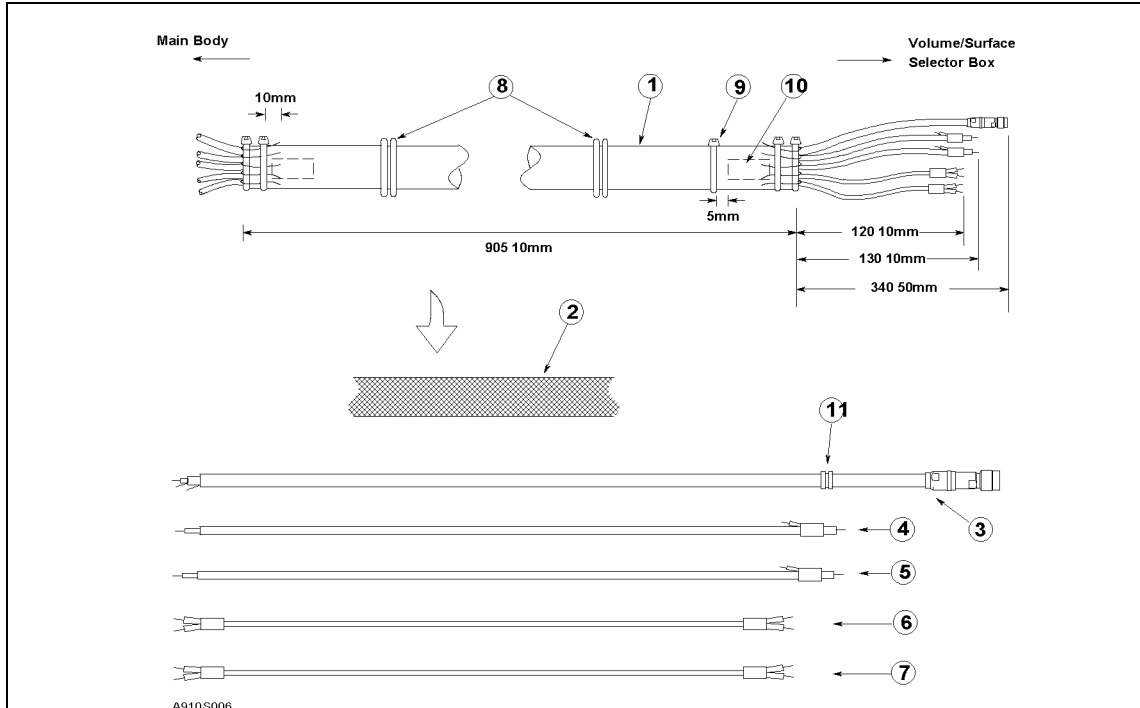

Reference Designator	Agilent Part Number	Qty.	Description
1	16008-61661	1	Cable Assembly ¹
2	0890-1649	115cm	Tube Flex
3	16008-61651	1	Cable Assembly(Triaxial)
4	16008-61654	1	Cable Assembly(Black Label)
5	16008-61655	1	Cable Assembly(White Label)
6	16008-61656	1	Cable Assembly(Black Label)
7	16008-61657	1	Cable Assembly(White Label)
8	0400-0276	2	Grommet
9	1400-1653	5	Cable Tie
10	16008-25061	2	Insulator ²
11	0400-0306	1	Grommet ³
12	16008-68061	3	Jumper Wire
13	16008-61652	1	Cable Assembly(BNC)
14	16008-61653	1	Cable Assembly(6-pin)

1 Includes a flexible tube (Item 2) and 5 cables (Item 3 through 7).

2 Inside of the flex tube.

3 Put Grommet on before inserting into the flex tube.

Assembly Replacement (Upper Electrode)

This section explains disassembly procedure and lists the replaceable parts for the upper electrode.

Upper Electrode Disassembly

Figure 4-6 gives the disassemble procedure for the upper electrode.

1. Remove the knob on the top of the box (marked with ①).
2. Remove two screws (marked with ②) on the side of the cover
3. Remove the cover by pushing the latches on both sides (marked with ③).
4. Remove the 4 screws on both sides of the electrode. Now the upper electrode assembly will separate into 2 parts.

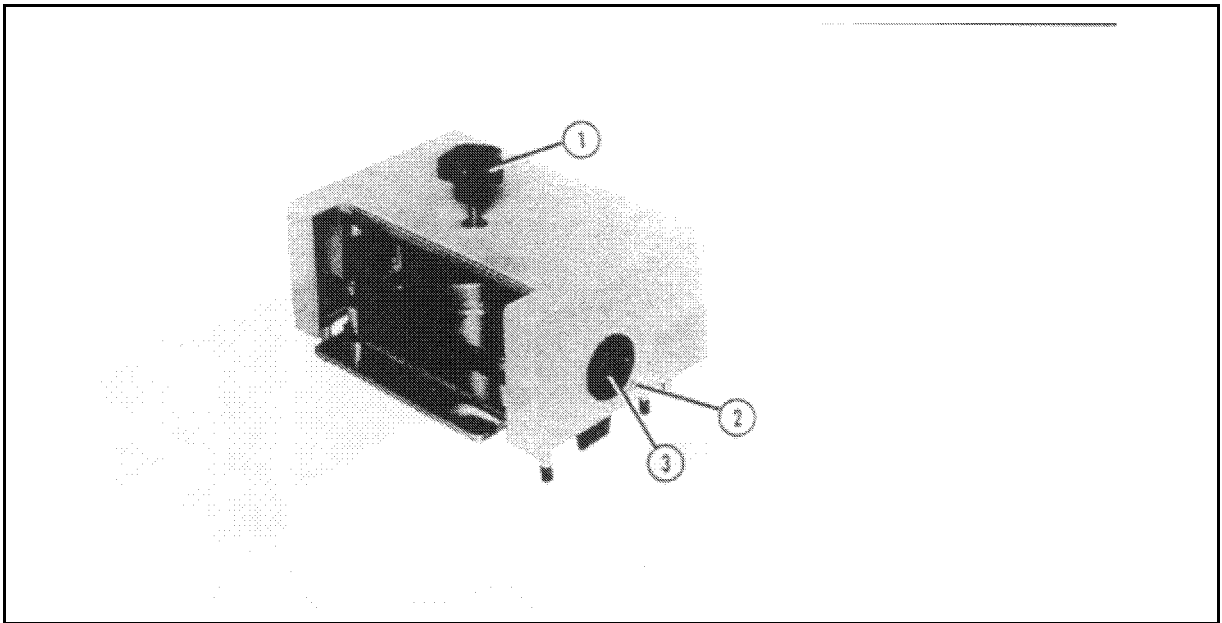
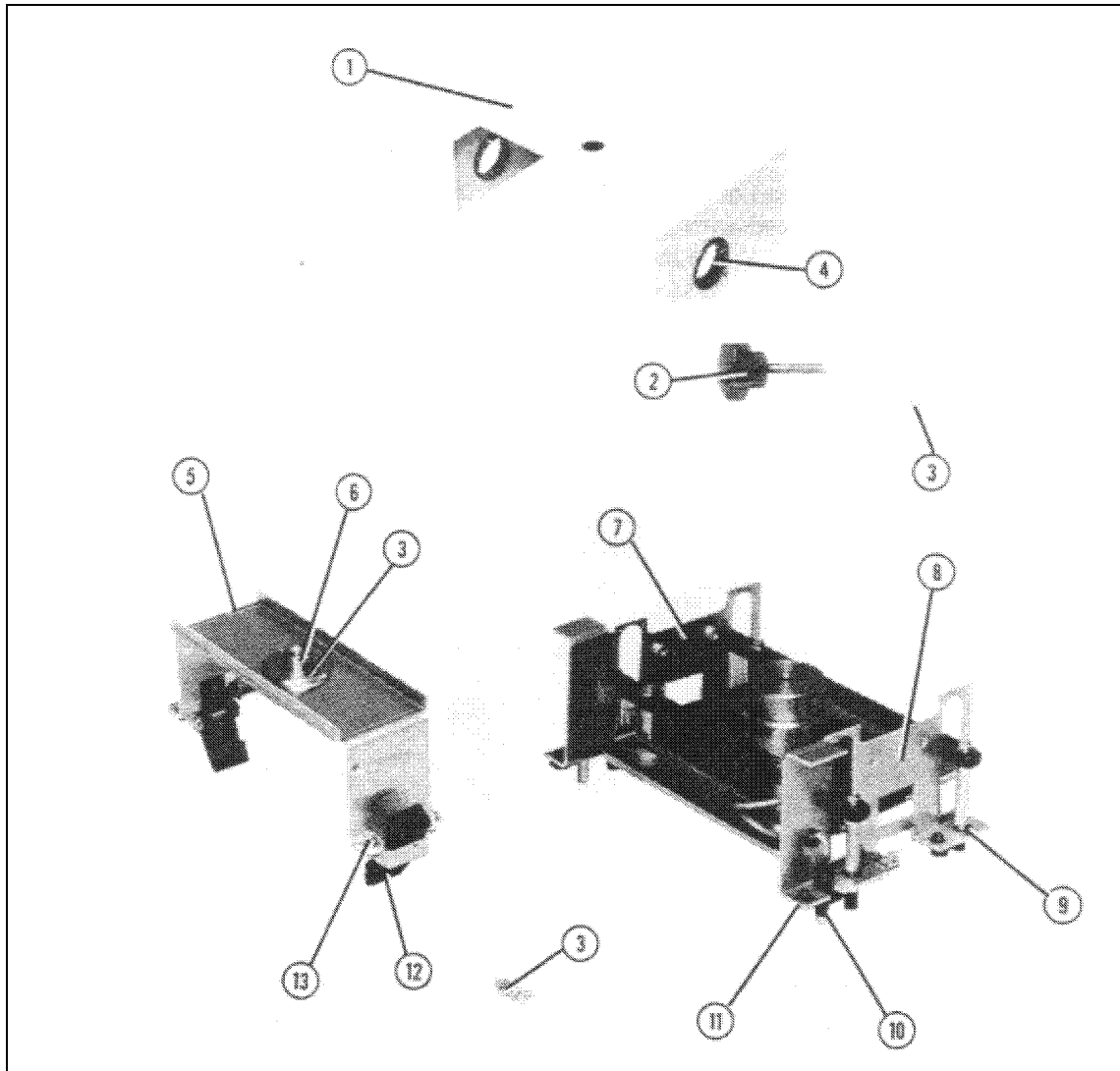

Figure 4-6. Upper Electrode Disassembly

Replaceable Parts

Table 4-9 and Table 4-10 shows and lists the replaceable parts for the upper electrode. The parts listed can be ordered from your nearest Agilent Technologies Office. Ordering information must include the Agilent part number and the quantity required.

Table 4-9. Replaceable Parts for Upper Electrode (1 of 2)



Reference Designator	Agilent Part Number	Qty.	Description
1	16008-60072	1	Top Cover
2	0370-3231	1	Knob
3	0515-0914	8	Screw Flat M3L6
4	16008-25073	2	Bushing
5	16008-00171	1	Chassis
6	16008-24074	1	Bushing
7	16008-00172	1	Chassis Side
8	16008-00173	1	Chassis Side
9	16008-25074	5	Bushing
10	16008-60074	1	Terminal Assembly
11	0403-0316	4	Bumper Foot
12	1390-0896	2	Latch
13	0515-1550	4	Screw Pan M3L8

Table 4-10. Replaceable Parts for Upper Electrode (2 of 2)

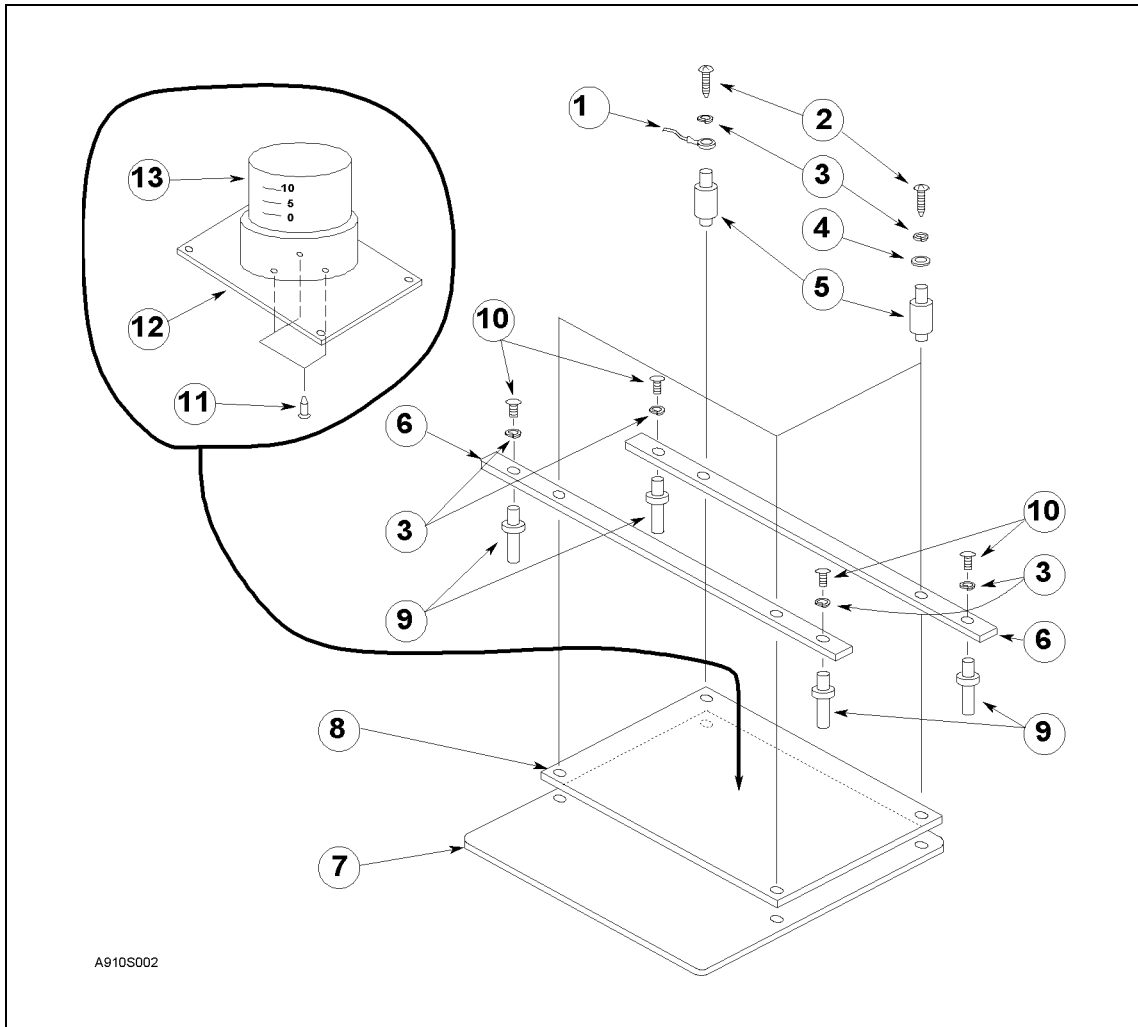

A910S002

Reference Designator	Agilent Part Number	Qty.	Description
1	16008-61671	1	Cable
2	0515-0919	4	Screw Pan M3L25
3	2190-0584	4	Spring Washer
4	3050-0891	7	Washer
5	16008-24076	4	Spacer
6	16008-25071	2	Beam
7	16008-20071	1	Electrode
8	16008-00671	1	Plate
9	16008-60075	4	Guide Pin
10	0515-1550	4	Screw Pan M3L8
11	0515-0907	2	Screw Flat M3L6
12	16008-00672	1	Plate
13	16008-60073	1	Spring Assembly

Assembly Replacement (Lower Electrodes)

This section explains the disassembly procedure and lists the replaceable parts for the lower electrodes.

Disassembly Procedure

See “Exchanging the Electrode” in Chapter 2 when disassembling the lower electrode.

Replaceable Parts

The kinds of electrodes and part numbers for each are shown in Table 4-11. The parts listed can be ordered from your nearest Agilent Technologies Office. Ordering information must include the Agilent part number and the quantity required.

Table 4-11. Replaceable Parts for Lower Electrodes

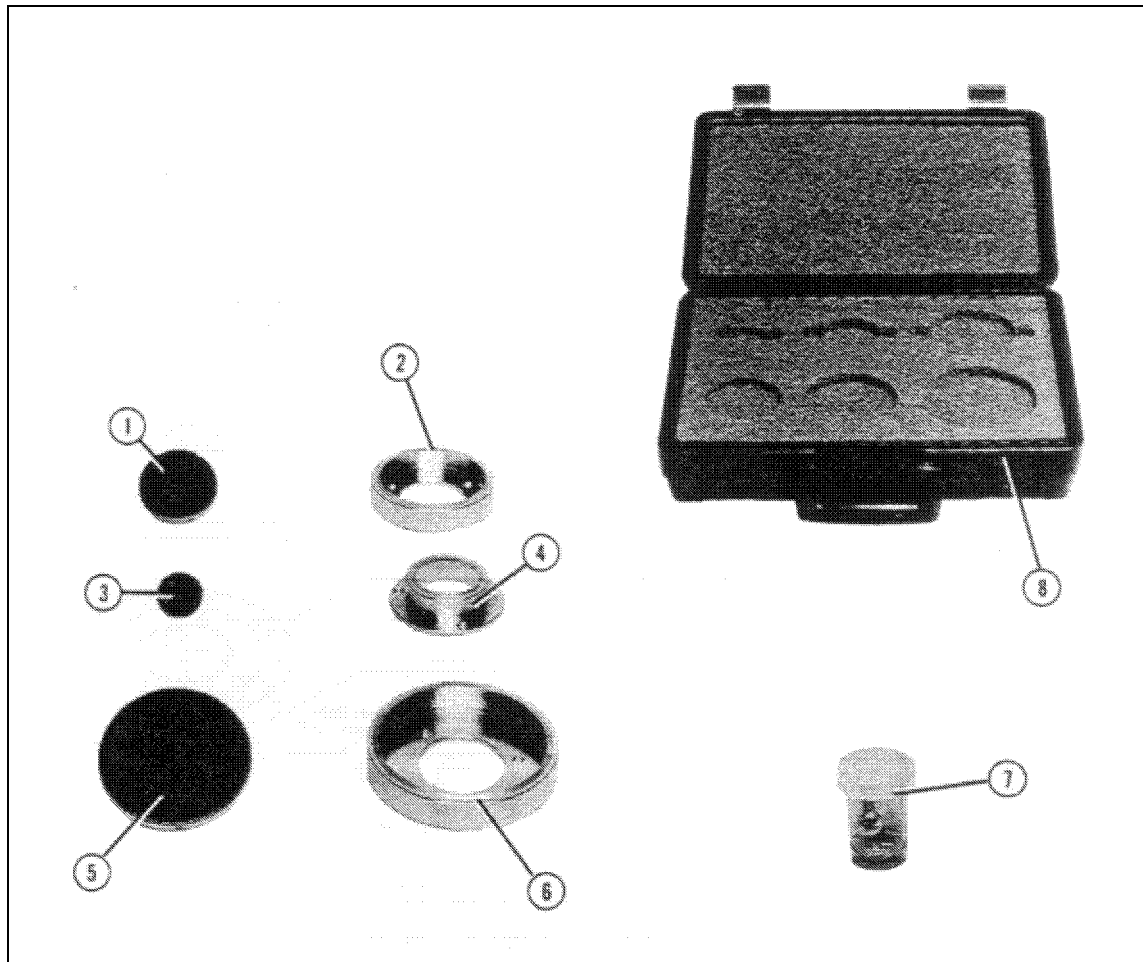

Reference Designator	Agilent Part Number	Qty.	Description
1	16008-60081	1	Main Electrode(ϕ 50mm)
2	16008-24082	1	Guard Electrode(ϕ 70mm)
3	16008-60083	1	Main Electrode(ϕ 26mm)
4	16008-24084	1	Guard Electrode(ϕ 38mm)
5	16008-60085	1	Main Electrode(ϕ 76mm)
6	16008-24086	1	Guard Electrode(ϕ 88mm)
7	16008-60088	1	Spare Screws ¹
8	16008-60181	1	Carrying Case

1 includes 3 screws (0515-0907) and a case (1540-0692).

Troubleshooting

This section includes the schematic diagram of the 16008B and gives some troubleshooting hints.

Schematic Diagram

Figure 4-7 is the schematic diagram of the 16008B.

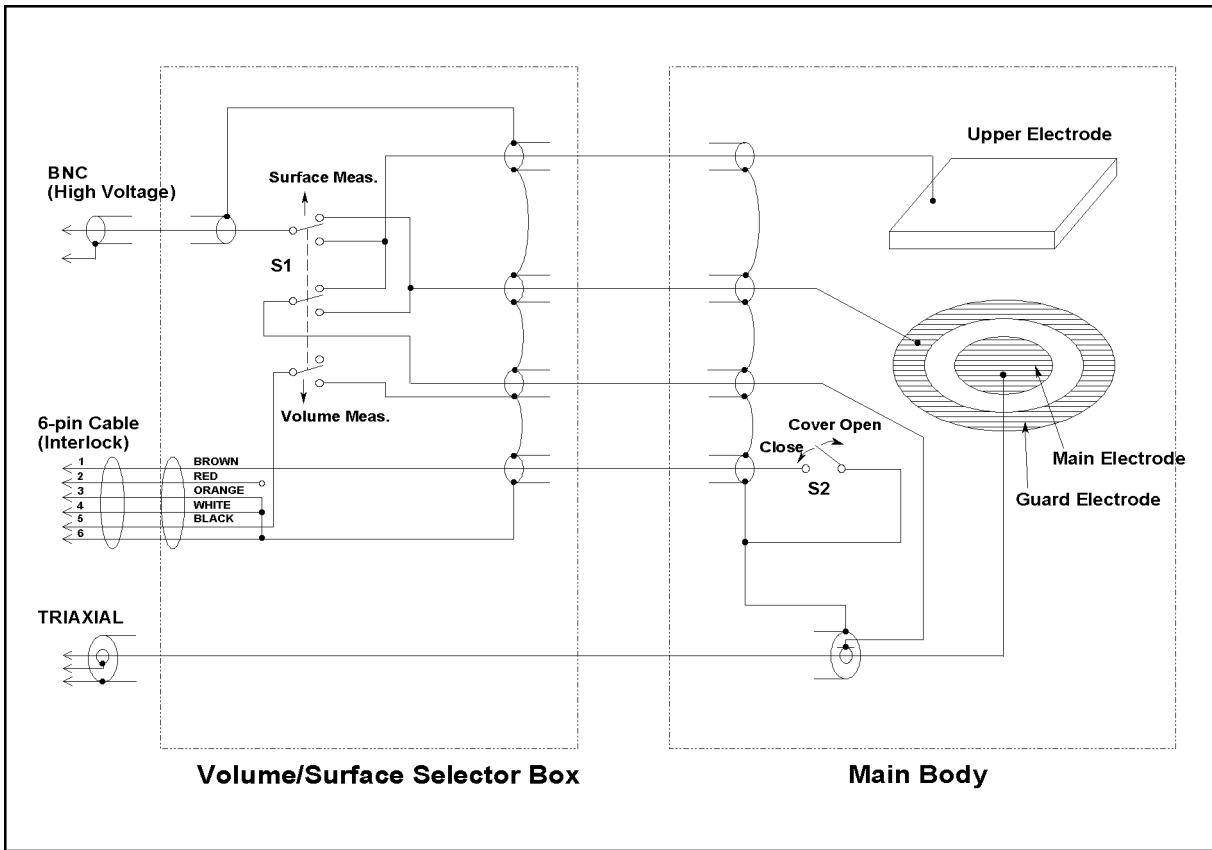

A910S001

Figure 4-7. Schematic Diagram of 16008B

Cable Connection Check

After repairing, check the cable connections listed in Figure 4-8 and Table 4-12 using a multimeter which has a low resistance range (1 or 2 Ω). The information in these lists can be also used for troubleshooting of the 16008A.

BNC Cable and Triaxial Cable Connection Check

Check the connections between the connectors and the terminals as shown in Figure 4-8.

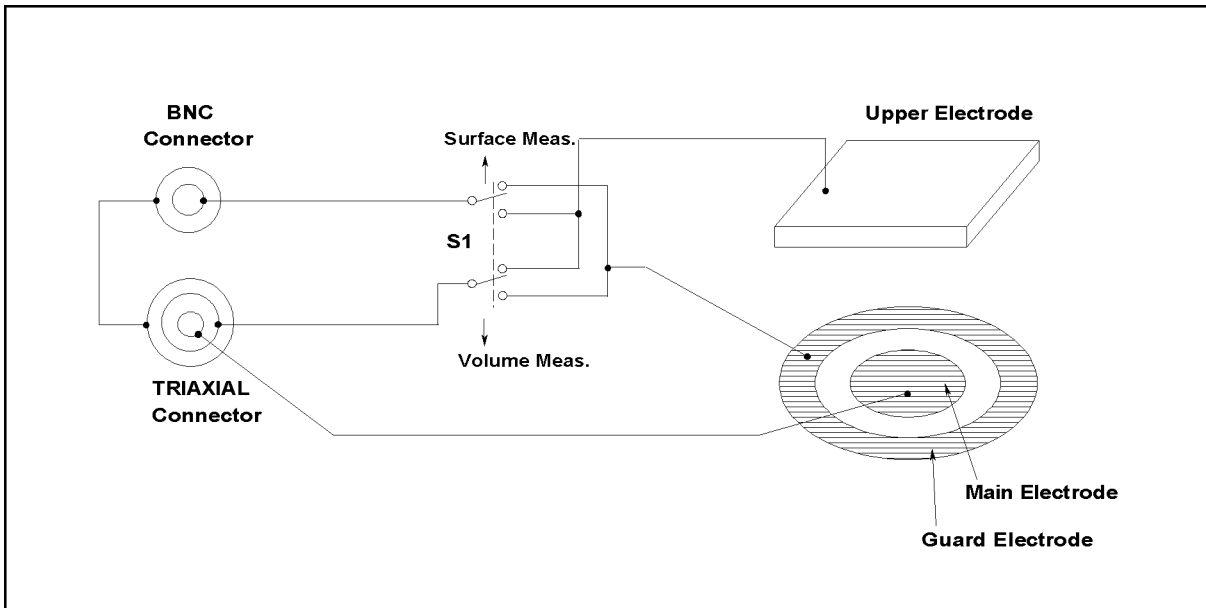

A910S011

Figure 4-8. Cable Connection Check

Interlock Circuit Connection Check

Interlock connector connections and its pin locations are shown in Table 4-12. Check the connections between each of the 6 pins and the outer conductor of BNC connector or the Triaxial connector.

Table 4-12. 6-pin cable connections

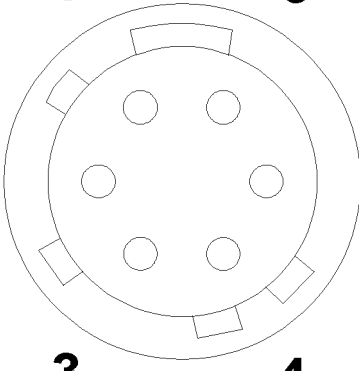

A910S007

Pin Number	Top Cover		Selector	
	Open	Close	Volume	Surface
1	NC ¹	GND ²	⇐	
2	NC		⇐	
3	GND		⇐	
4	GND		⇐	
5	⇒		GND	NC
6	GND		⇐	

1 means "Not Connected".

2 Touch the BNC outer conductor for GND.